

emco group

Designed for your profit

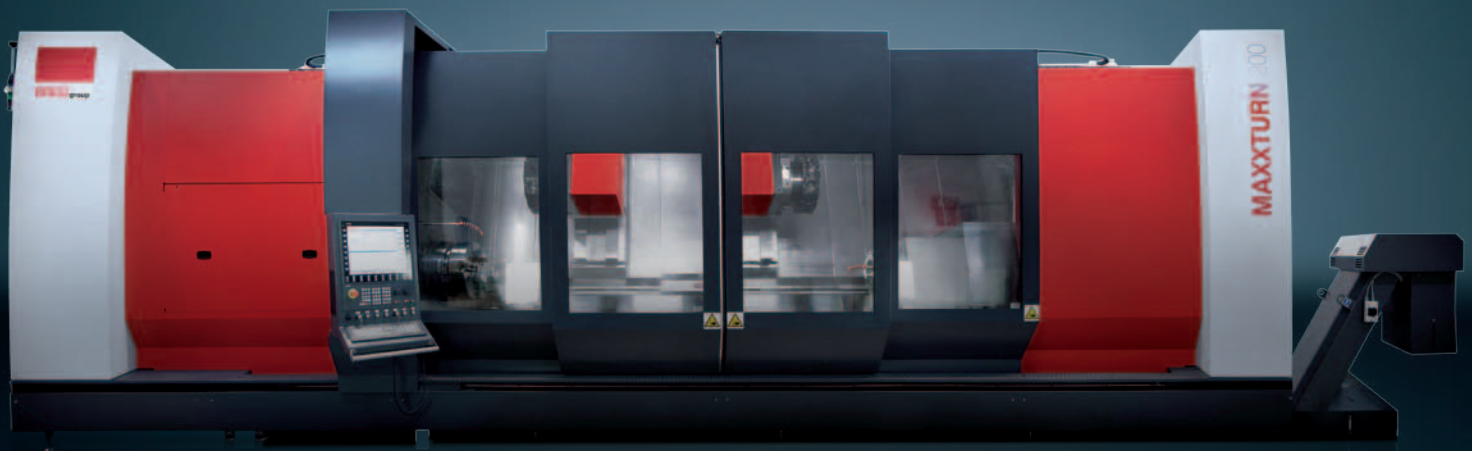

EMCO MAXXTURN 200

Universal turning centre for complete machining
of shaft and chuck parts

TURNING
EMCO-WORLD.COM

EMCO MAX

1 CONTROL

- Ergonomic, swivel-mounted and movable control panel
- Sinumerik 840D sl with 22" colour display
- Comprehensive machining cycles
- 3D simulation
- USB interface, 230 V socket
- emcoNNECT
- EMCO technology cycles (optional)

2 WORK ZONE

- 3 bed lengths
- Ideal accessibility is guaranteed by the 70-degree inclined bed and the machine concept
- Maximum productivity thanks to 2" turret with or without Y-axis
- Work zone and counter spindle with flush system
- Maximum flexibility thanks to several turret concepts

3 TOOL TURRET AND Y-AXIS

- +/- 125 mm stroke
- 90° design integrated in the machine structure
- Wide and stable guide structure for ideal vibration damping

4 CHIP CONVEYOR

- Hinged-slat chain conveyor with 1150 mm ejection height
- Suitable for: long steel chips, chip balls, woolly chips, dry and wet machining
- With built-in coolant system
- Paper belt filter equipped with high-pressure pumps with up to 80 bar (optional)



Machine with optional extras

MAXXTURN 200

The solid Maxxturn 200 heavy-duty cutting machine can be used for turning and milling operations. Parts featuring a maximum length of 6000 mm and a diameter of 1000 mm are produced with ease and high efficiency. The machine is available in the following configurations: with 2 turrets (standard or mirror-inverted version), with tailstock or equipped with a counter spindle.



5 MACHINE BED

- Broad distance of the guide rails
- Largely dimensioned roller guides
- Maximum stability
- Maximum pre-stressing guarantees zero play in all directions of force
- Slide way for the X-axis and the tailstock Z-axis too
- Tailstock or counter spindle unit

6 STEADY REST SYSTEM

- In different dimensions
- NC steady rest or tandem steady rest
- Easy to remove
- Sealing air, cover and flush system included in the standard version
- Optional: programmable pressure adjustment

7 TAILSTOCK (COUNTER SPINDLE)

- NC tailstock
- Built-in bearing for MK6 centre point
- 200 mm quill diameter
- 250 mm quill stroke
- Automatic pressure monitoring of the quill position

8 MACHINE CLADDING

- Comprehensive protection against flying chips
- 100% protection against coolant leakage
- Large door made of safety glass
- Unobstructed view into the work zone

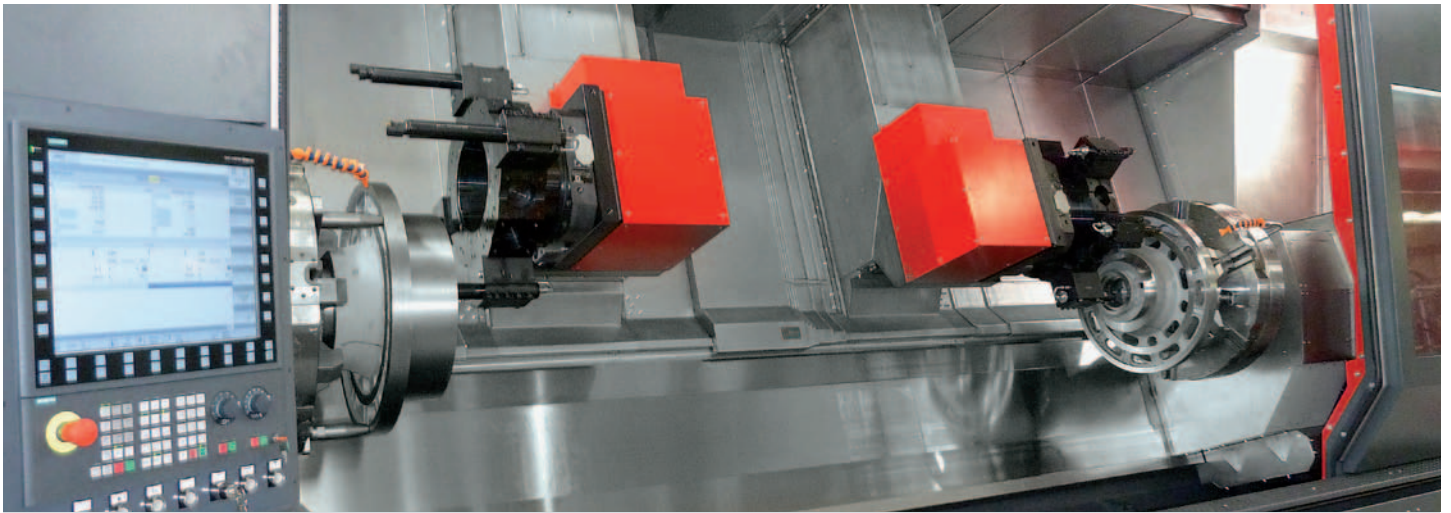

The Maxxturn 200 machine concept: Best turning and milling performance in all production runs. Stable machine concept that enables complete machining of long and large workpieces. The large door opening and the swivel-mounted control panel ensure ideal and ergonomic machine operation.



The Maxxturn 200 comes in modular design. Different upgrading levels allow everything from simple turning to the expansion to a turning and milling centre with versatile application possibilities. Different spindle concepts with C-axis and high torque are used.

MAXXTURN 200 Technical

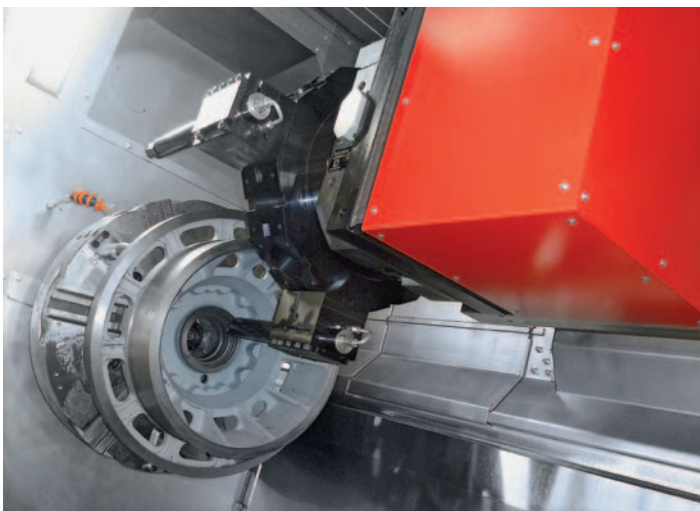

Machining possibilities: Versatile machining operations are possible thanks to the BMT85 and/or VDI60 12-station turret with driven tools and block tools for large drill rods. When used in conjunction with the 80 bar belt filter system/coolant preparation, the coolant volume as well as the quality and the service life of the cutting fluid are increased.

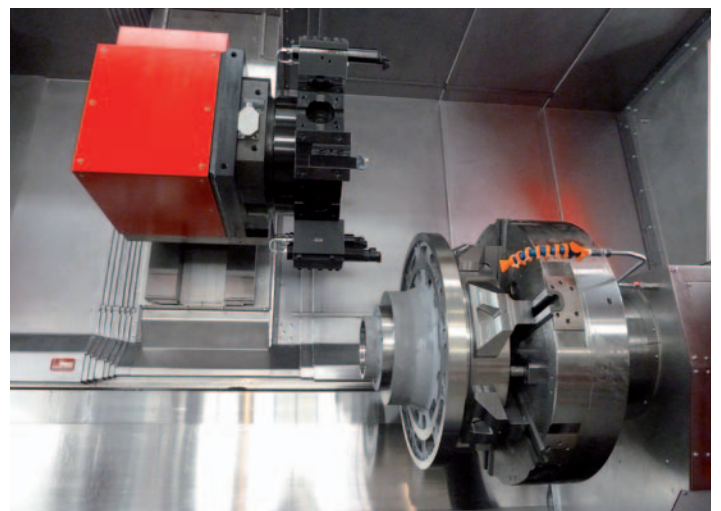

BMT turret: The machine's standard equipment includes one or two BMT85 12-station turrets. With a maximum of 3000 rpm, 116 Nm and 19.8 kW, this turret creates the ideal conditions for complete machining and maximum productivity. A VDI60 12-station turret is available as an option.

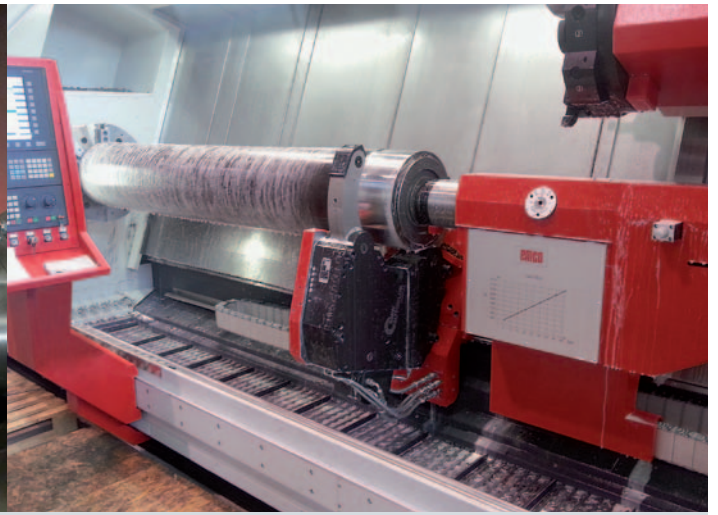
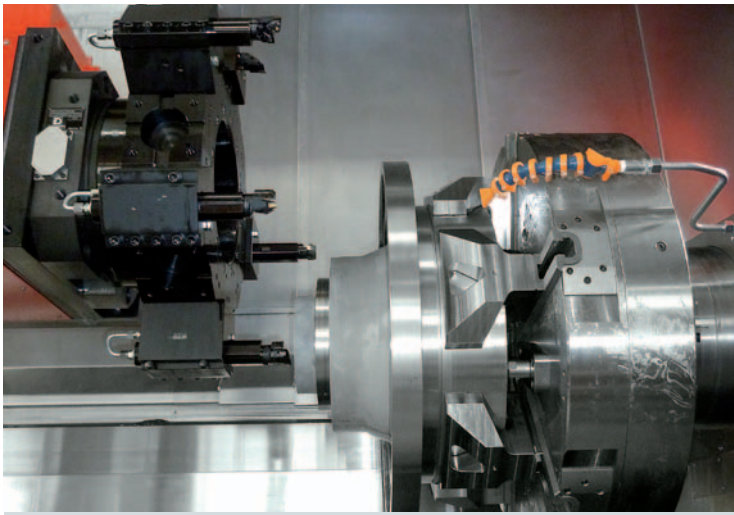

Tailstock / counter spindle: The machine is equipped with an NC-controlled tailstock (optional) with integrated bearing and MK6 quill. Workpieces with a maximum weight of 6 tons are thus supported in a safe and stable condition. With the optionally available counter spindle, it is possible to manufacture workpieces in one cycle and/or two workpieces at the same time.

Highlights

Highlights

- Extremely robust design
- Maximum machining accuracy
- High rapid traverse speeds
- Stable Y-axis with large travel (MT200 +/- 125 mm)
- MT200 NC steady rest, tailstock or counter spindle included as standard
- Hydraulic spindle brake
- State-of-the-art control technology
- Driven tools including C-axis
- Simple, dialogue-based programming



High-precision Y-axes: The Maxturn machine concept has been designed in such a way that the Y-axis is fitted at an angle of 90°. Due to large, widely spaced and prestressed linear roller guide rails, this Y-axis ensures optimum machining results with maximum stability and short projection lengths (possible for up to two turrets).



Control system: The machine is equipped with a Siemens 840D sl control. The scope of delivery includes a 22" display with state-of-the-art emcoNNECT control panel as well as versatile EMCO technology cycles (optional) for easy, dialogue-based programming.

Performance Diagrams

Different, standardised turret/spindle solutions are available as an option: BMT or VDI, with 11" or 15" spindle solution. Ideal performance and optimum torques for each type of machining are achieved by the perfect interplay between the mechanical components and the control.

Main spindle (KK15")

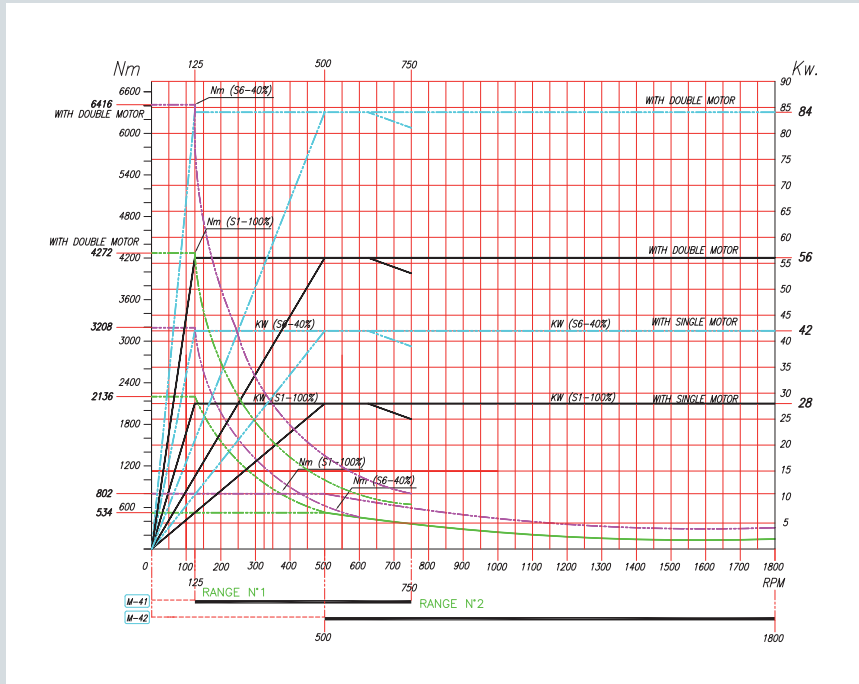

Counter spindle (KK15" or 11") Main spindle (KK11")

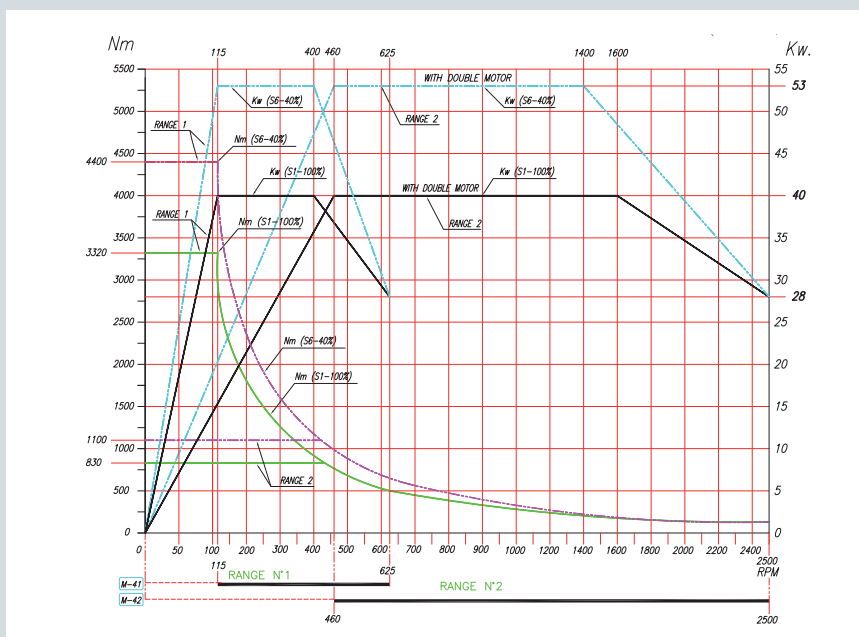

MT200 – The master/slave motor arrangement, which also serves as the C-axis, has been implemented **with the EMCO spindle concept**. The motors run in sync, guarantee compensation for play and make it possible to achieve the performance values and torques mentioned below (see diagrams).

Additionally, the two motors are equipped with ZF Duoplan Two-Speed Gearboxes. This results in high torques in the lower speed range and in high speeds in the upper speed range. Thus, it is possible to make optimal use of the cutting capacity provided by modern tools.

The Siemens 840D sl controls the two motors synchronously, which results in zero-play C-axis operation. Besides, the main spindle is equipped with a special EMCO cooling system that guarantees temperature stability and maximum precision irrespective of the machining length.

MT200 - BMT 85 driven tools

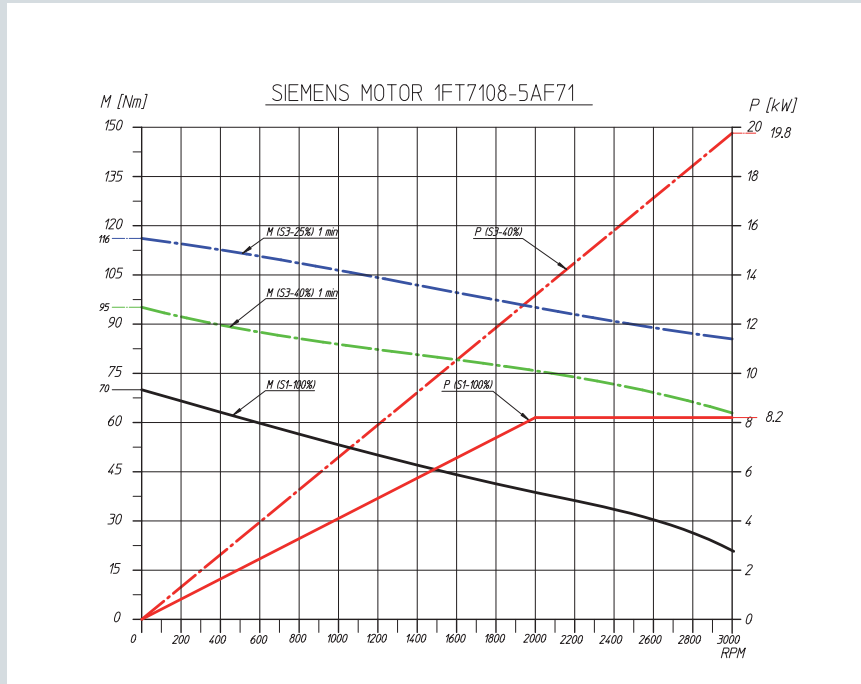

*optional

MT3200 – Modular system

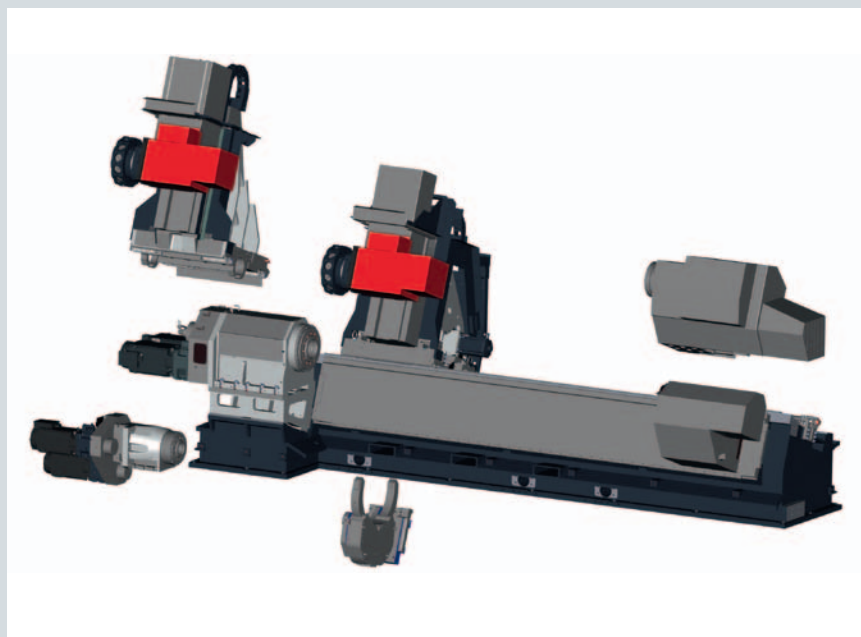

*optional



DASHBOARD – For a Quick Overview of the Machine Status

Clear and compact processing of all relevant machine and NC data depending on the configuration of the machine (number of tool systems, spindles, ...) and the active operating mode (JOG, MDA, AUTO). Know at a glance whether everything is OK or whether the machine operator will be required to interact.



emcoCONNECT's hardware basis is a 22" industrial touch control panel combined with an industrial PC (IPC).

Highlights

- Direct interaction between EMCO Apps and the control
- Intuitive user interface optimized for touch control
- Range of available applications is continuously being expanded
- Customised and project-specific applications
- Optimized for the EMCO machine range
- emcoCONNECT allows for easy and quick configuration and updating

er“ for fire production flow

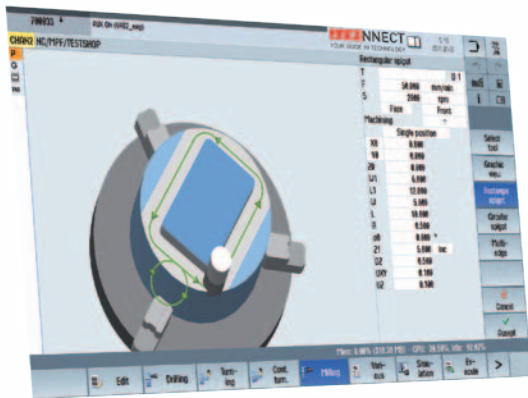

SINUMERIK - the Control and the Machine's Centerpiece

Thanks to the App Launcher operators may switch between the emcoCONNECT Apps and the control at any time. All it takes to do so is a click on the emcoCONNECT logo. To improve the work processes on the machine the control can, as shown in the picture, be operated in full screen mode or in interaction with practical apps (sidebar).

MACHINE DATA – All Data related to Productivity at a Glance

Operating data collection to inform the user about the current production status and OEE (Overall Equipment Effectiveness) values full screen or sidebar.

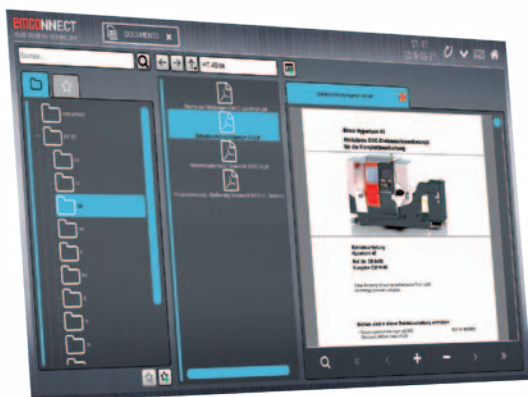

DOCUMENTS – A Digital and Expandable Document Collection Customised to Suit Your Individual Needs

To display PDF documents such as machine documentations, programming instructions, process descriptions ... Including favourites management - full screen or sidebar

MAXXTURN 200 – Work Zone

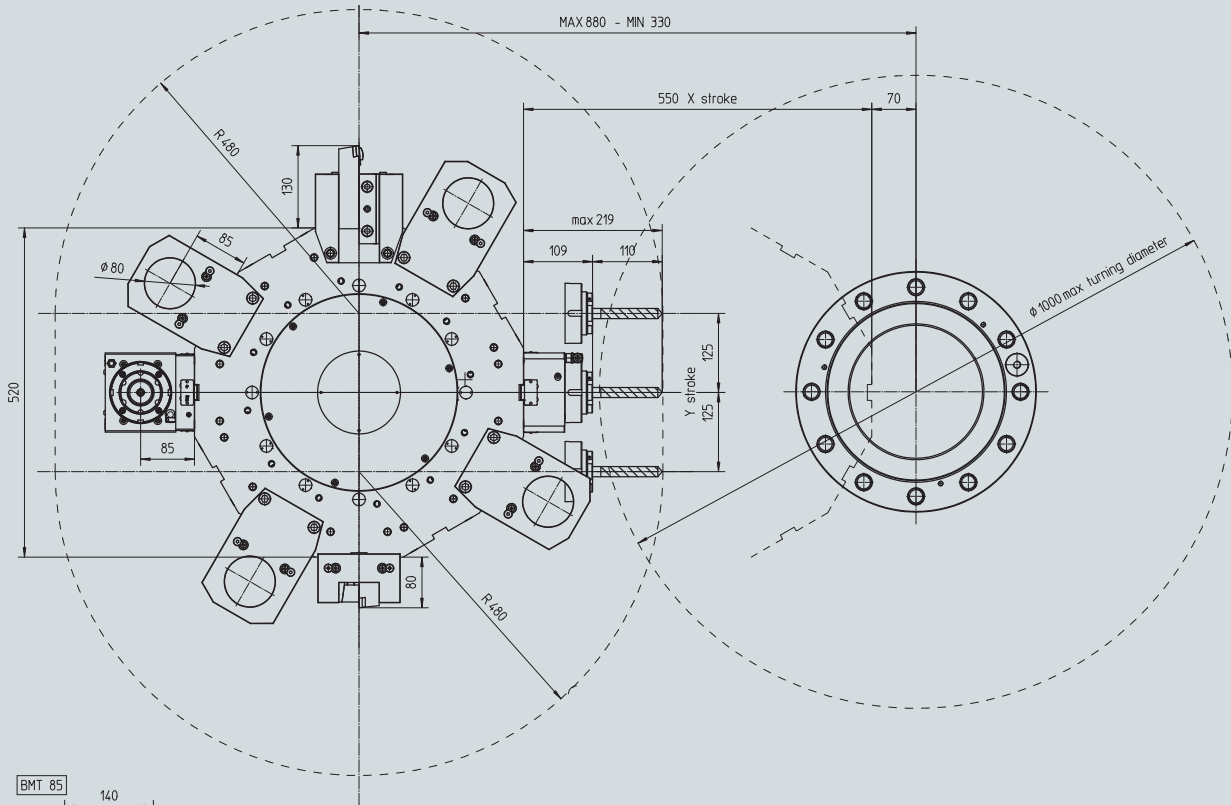

*Other machine lengths available on request

D.P.	A	B	C	D
2000	2020	2200	2050	1600
4000	4020	4200	4050	3600
6000	6020	6200	6050	5600

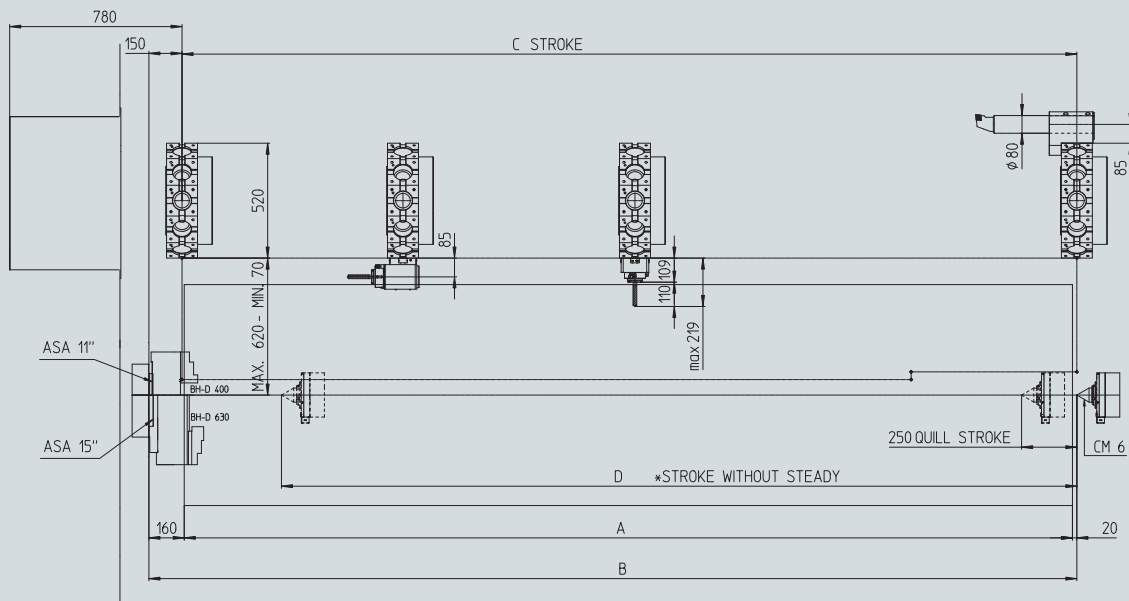

Data indicated in millimetres

MAXXTURN 200 – Floor Plan

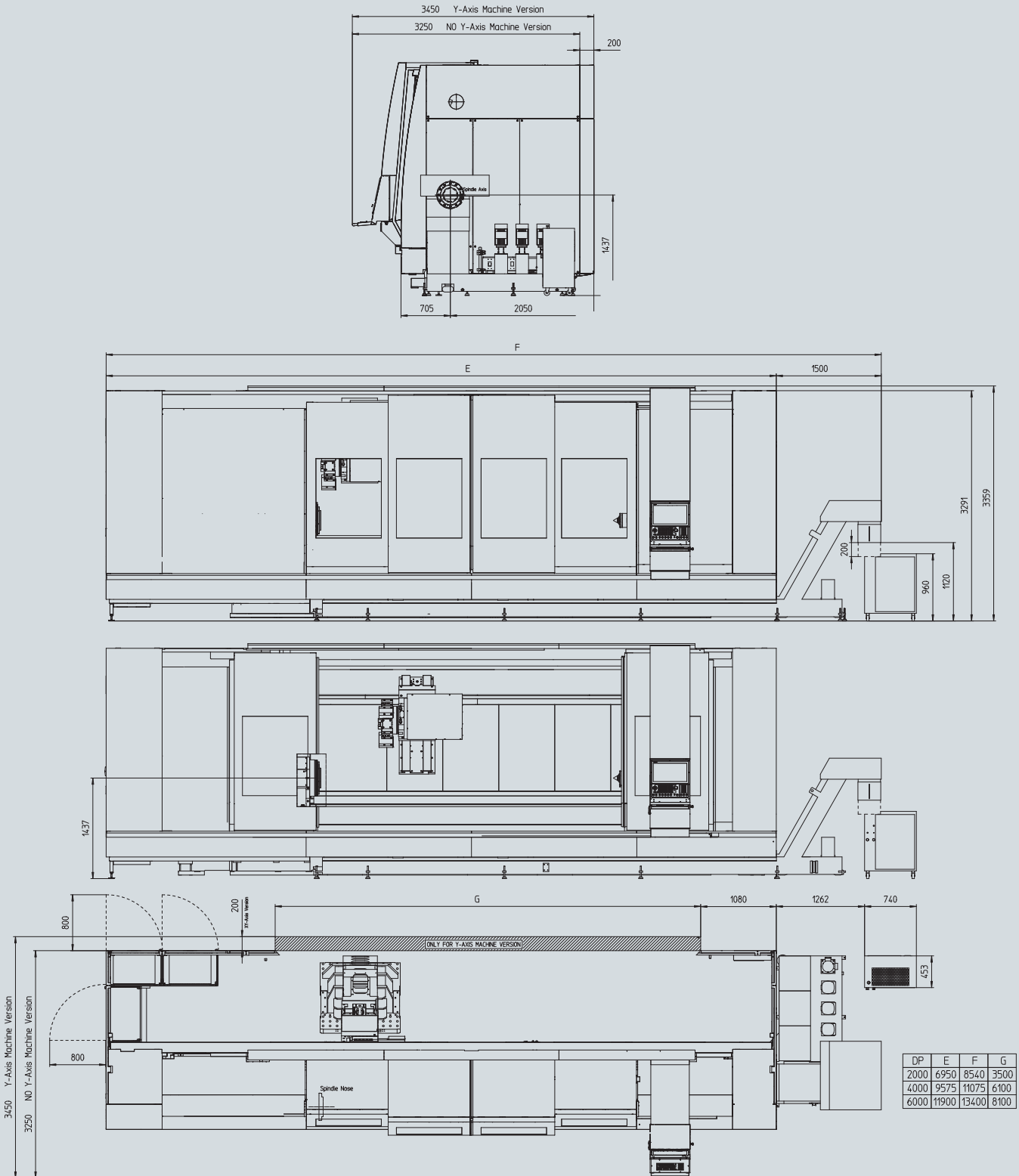

Data indicated in millimetres

MAXXTURN 200

Technical Data

Working area

Swing over bed	1050 mm
Distance between centres (spindle nose to live centre)	2200 / 4200 / 6200 mm
Max. turning diameter	1000 mm
Max. part length	2000 / 4000 / 6000 mm
Max. workpiece weight (overhung)	1500 Kg
Max. workpiece weight between tailstock and chuck (incl. chuck)	6000 Kg

Travel

Carriage travel in X	550 mm
Carriage travel in Z	2050 / 4050 / 6050 mm
Carriage travel in Y	+/- 125 mm

Main spindle – A2-15" DIN 55026 (ZF gearbox)

Max. speed range	0 – 1800 rpm
Max. capacity, AC hollow spindle motor	84 kW
Max. torque	6410 Nm
Spindle bearing (inner diameter, front)	280 mm
Max. chuck diameter	500 (800) mm

C-axis (with A2-11" spindle)

Axis resolution	0,001°
Max. torque	5000 N

Main spindle - counter spindle A2-11" DIN 55026 (ZF gearbox)

Max. speed range	2500 rpm
Max. capacity	53 kW
Max. torque	4400 Nm
Spindle bearing (inner diameter, front)	190 mm
Max. chuck diameter	500 (800) mm

C-axis with A2-11" spindle

Resolution of the rotary axis	0,001°
Max. torque	4400 Nm

Tool mover (standard version)

Number of tool positions (all driven)	12
Tool holder	BMT85

Tool mover

Speed range	3000 rpm
Drive performance	19,8 kW
Torque	max. 116 Nm

Feed drives

Rapid traverse speed X / Z / Y	15 / 30 / 30 m/min
Feed force, X-axis	30000 N
Feed force, Z-axis	30000 N
Feed force, Y-axis	20000 N

Tailstock with quill

Quill stroke	250 mm
Quill diameter	200 mm
Max. contact pressure	40000 N
Holder (with built-in bearing)	MK 6

Coolant system (integrated in the chip conveyor)

Tank capacity BL 2200 / 4200 / 620	500 / 600 / 700 litres
Coolant pressure	20 bar

Power consumption

AConnected load (15"/11" spindle)	118/86 kVA
-----------------------------------	------------

Dimensions

Height of the rotary axis above floor level	1440 mm
Height of the machine	3360 mm
Footprint W x D BL 2200	8600 x 3450
Footprint W x D BL 4200 / 6200	11100 / 13400 x 3450
Total weight including chip conveyor	ca. 30 / 40 / 50 t
BL 2200 / 4200 / 6200	