

emco group

Designed for your profit



HYPERTURN 65 Powermill

High-performance turning/milling
center for complete machining of
complex workpieces in one operation

TURNING
EMCO-WORLD.COM

HYPERTURN

1 UPPER Y AXIS

- Large working stroke +120 / -100
- Short cantilever length
- Pre-loaded roller guides
- Wide guide clearance

2 UPPER TOOL SYSTEM

- Powerful milling spindle 29 kW
- Wide speed range 0-12000 (18000) rpm
- Water-cooled motor spindle with HSK-T63
- Internal and external coolant supply
- B axis with zero backlash direct drive
- B axis position can be fixed in any position

3 MAIN SPINDLE

- Integrated spindle motor (ISM) in synchronous technology - water-cooled
- High drive power 29 (37) kW
- High torque 250 (360) Nm
- Large speed range 0 - 5000 (4000/3500) rpm
- Highly dynamic
- Bar capacity diameter 65 (76/95) mm

4 TOOL MAGAZINE

- 20-slot disc-type tool magazine
- 40/80/120-slot chain-type tool magazine
- Ergonomically arranged up front
- Easy to be manually loaded with tooling
- Max. tool length 250 mm
- Max. tool diameter 80 (120) mm
- Max. tool weight 5 kg

5 LOWER TOOL SYSTEM

- 12-station tool turret
- VDI30- (VDI40- or BMT55P-) quick-change system
- 12 driven tool stations
- Servo-controlled
- Rigid tapping
- Polygonal turning, etc.

6 Lower Y axis

- Travel +/- 50 mm
- Stable, compact construction
- Wide guide clearances
- Tapered carriage system
- Max. tool weight 5 kg



Sprocket-wheel
(Steel Ck 45)



Bonnet flange
(Brass)

65 Powermill

More clearance, more power, more possibilities: with a spindle distance of 1300 mm, a powerful counter spindle which also allows 4-axis machining, a B-axis with a direct drive for complex 5-axis simultaneous milling operations, an additional Y-axis for the lower turret, and all proven, high-quality features of the Hyperturn series, the Hyperturn 65 Powermill is a powerful addition to every machine range.



7 COUNTER SPINDLE

- Integrated spindle motor (ISM) in synchronous technology - water-cooled
- High drive power 29 kW
- High torque 250 Nm
- Wide speed range 0-5000 rpm
- Coolant feed internal for flushing
- Automatic part ejector

8 CHIP CONVEYER

- Hinged type conveyor belt
- Throw-off height 1200 mm
- Integrated coolant tank 400 l
- Turret pumps: 2 x 14 bar
- Flushing pumps: 2 x 3,7 bar

9 CONTROL UNIT

- Ergonomically designed
- 90° pivot and slidable
- Siemens Sinumerik 840D sl
- LCD color monitor 15"

10 FINISHED PART CONVEYOR

- Max. work piece size $\varnothing 95 \times 200$ mm
- Max. finished part weight 4,5 kg
- Storage area 230 x 1000 mm

11 WORK AREA

- Generous design
- Straight chip fall
- Optimum access to the work area



Sensor housing
(Stainless steel)



Knee
(Steel 16 Mn Cr5)

Hyper-Flexibility

1 THREAD MILLING

2 3D FREE-FORM MILLING

3 TURN-MILLING OF
ECCENTRIC DIAMETER

4 MILLING SLANT SLOTS

5 UNDERCUT FORM E/F

6 CONTOUR MILLING (ELLIPTICAL)

7 HOLE PATTERNS CENTERING, DRILLING,
TAPPING RESP. GROOVING

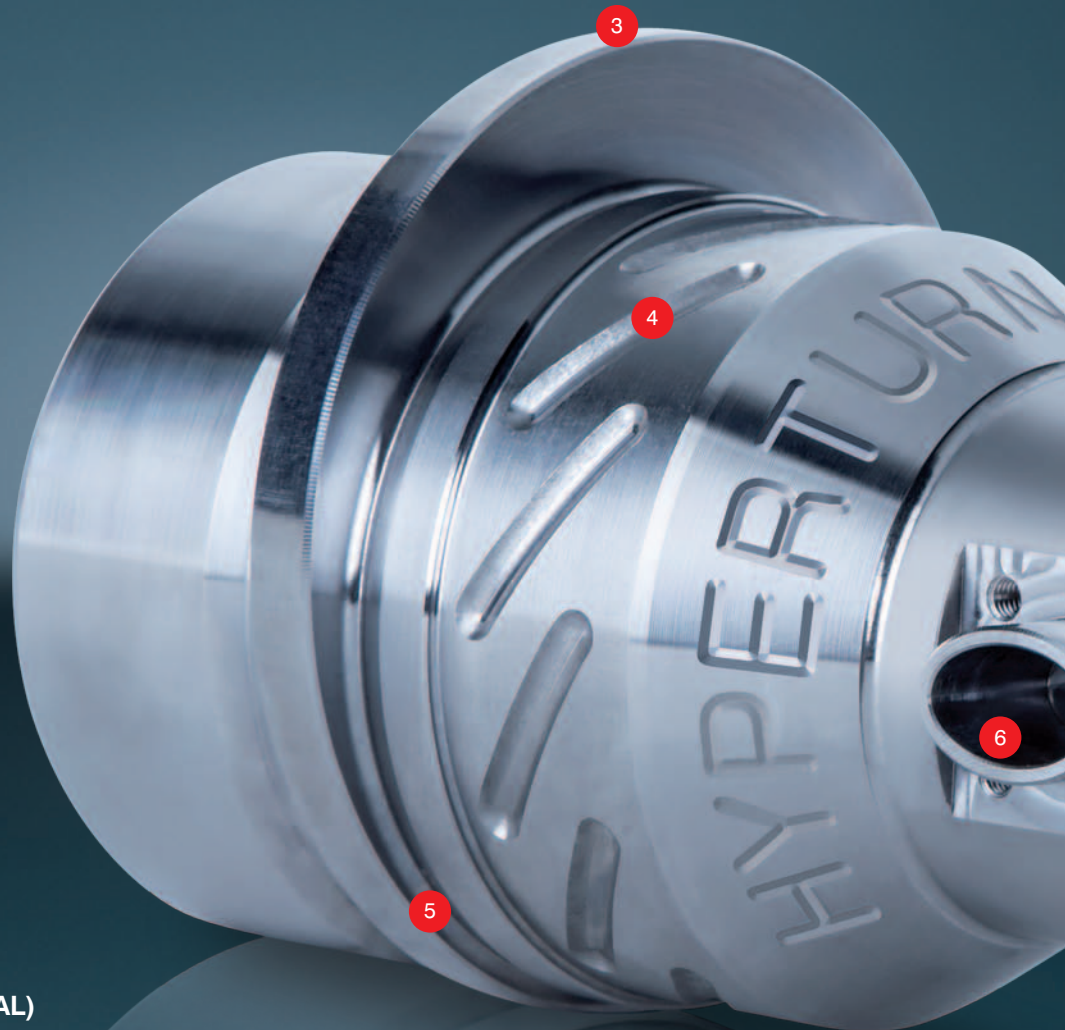

Machine flexibility is often sacrificed for the sake of productivity. Not with the HYPERTURN: with its high-performance and exceptionally mobile milling spindle and an almost inexhaustible tool magazine, the HYPERTURN can do nearly anything - and very quickly.

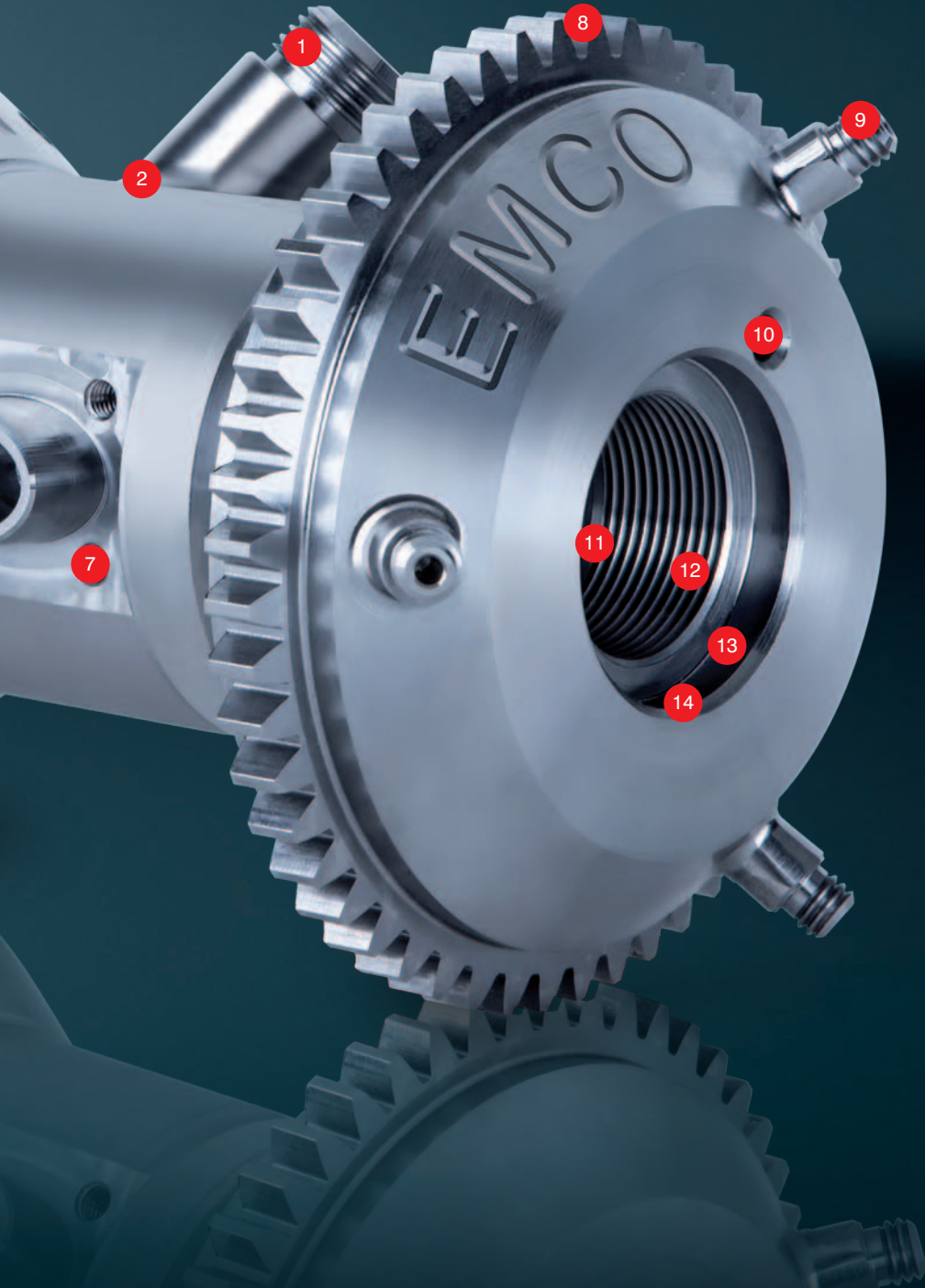

8 GEAR MACHINING
(GEAR HOBBIING)

9 CIRCULAR SPITGOT MILLING

10 DEEP-HOLE DRILLING

11 I.D. GROOVING

12 I.D. THREADING

13 I.D. BORING

14 AUTOMATED IN-PROCESS
MEASURING

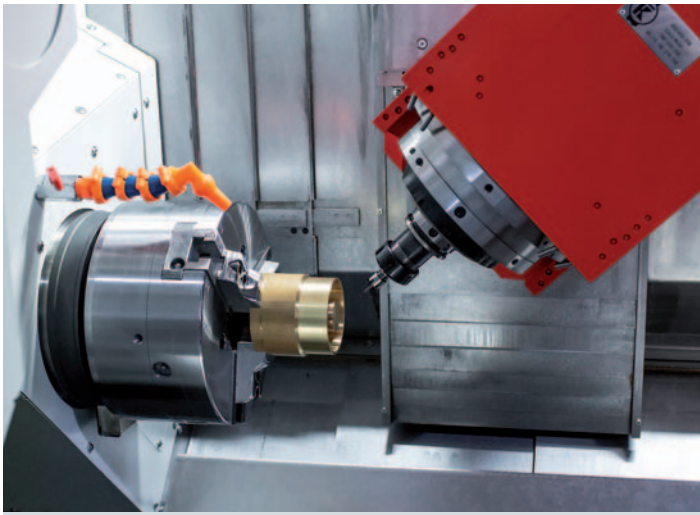

Main spindle. With an output of 29 (37) kW and 250 (360) Nm torque, the main spindle is powerful enough to machine from bar-stock up to a diameter of 65 (76/95) mm and chuck parts up to a diameter of 250 mm. A mechanical clamp brake ensures additional stability for high-performance milling.

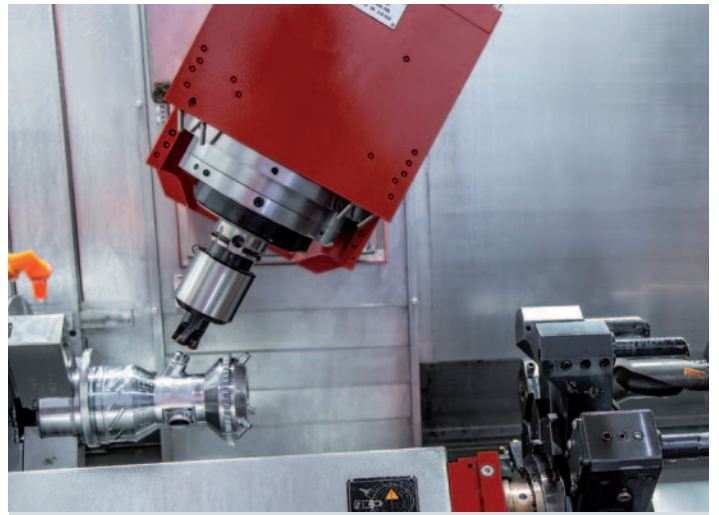

Milling spindle. At 29 kW/79 Nm and a max. speed of 12000 (18000) rpm, the HYPERTURN 65 PowerMill supports state-of-the-art milling processes such as HSC or HPC. This means that complex turned and milled parts can be produced in an extremely efficient manner.



Manual tool changing. Tools can be loaded into the tool magazines from the front. This avoids the need for the user to go to the rear of the machine. Also tool wear or break inspections can be handled in a time-saving way.



Tool measuring. The tool measuring arm in the workspace enables fast and precise measuring of tools in the workspace. It is mounted manually in the bracket below the main spindle and returned to a storage tray after use.

HYPERTURN 65 PowerMill Technical

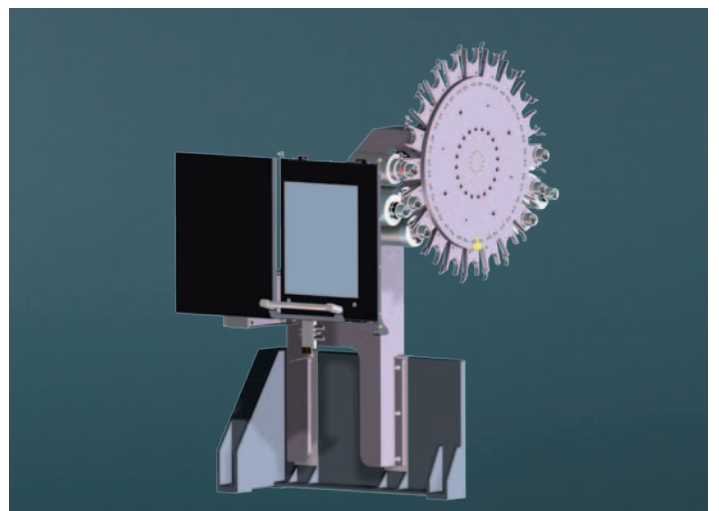

20-slot magazine. The tools are stored in a 20-slot tool disc. The milling spindle simply puts the last tool into an empty position, indexes to the next tool and picks it up.

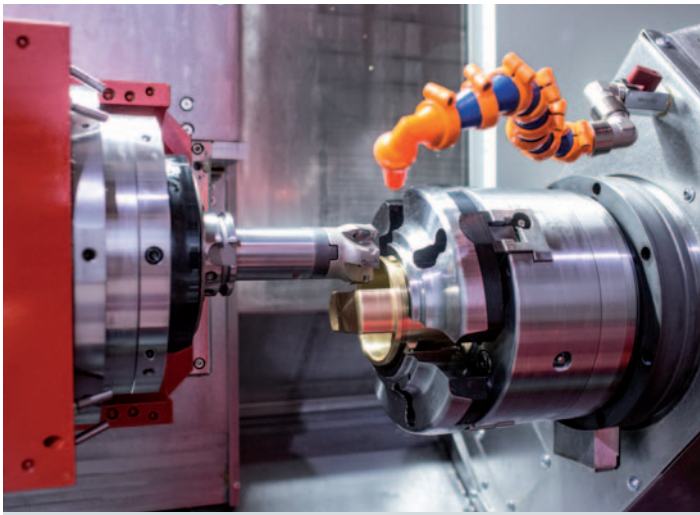

Counter spindle. The moving counter spindle offers identical performance data to the main spindle. The mechanical disc brake is also included in the basic equipment level. Additionally, a stroke-monitored part ejector that is flooded with coolant is integrated into the spindle. This ensures a reliable, unmanned machining process.

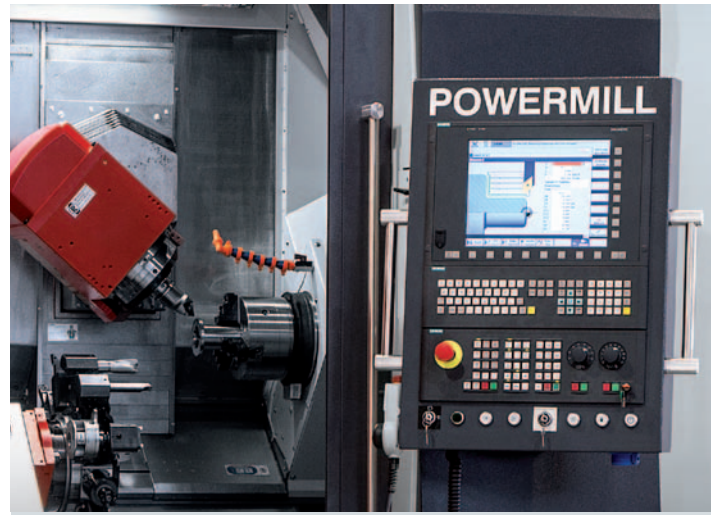

Control unit. The Sinumerik 840D sl control unit is located on the right of the workspace on the HYPERTURN 65 PowerMill in a sliding panel and can be swivelled in. This ensures maximum ergonomics for the set-up and running in the machine.

mill Highlights

Highlights

- High dynamics due to state-of-the-art spindle motor technology
- All spindles liquid-cooled for optimum thermostability
- High productivity due to short tool change times
- Both tool systems can be used on both spindles
- Bed design for maximum stability and oscillation damping
- Excellent repeatability due to linear guides
- Short set-up times due to ease of access to work area

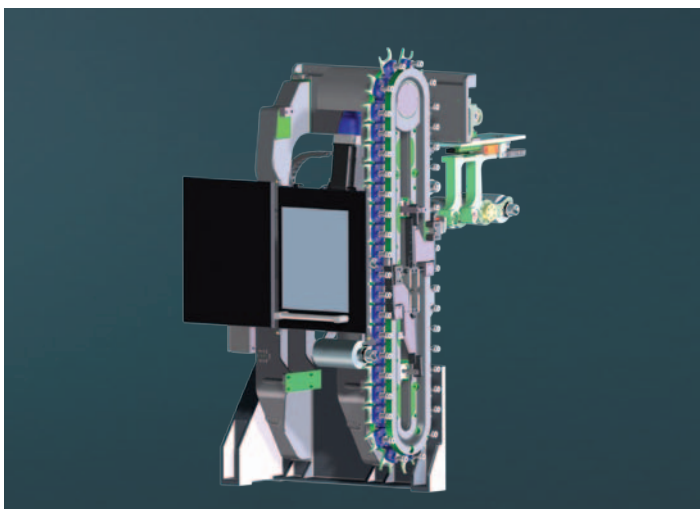

40-slot magazine. The chain magazine can hold up to 40 tool holders with HSK-A63 and HSK-T63 shafts. A pivotarm changer changes the tool into the milling spindle.

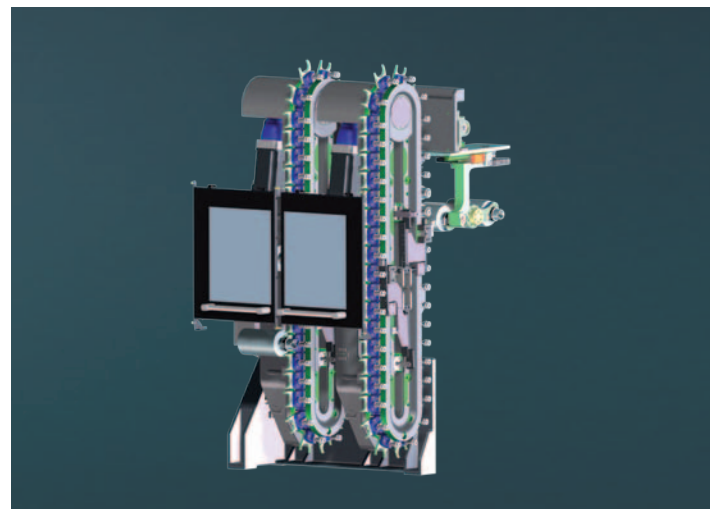

80-slot magazine. Two 40-slot chain magazines can be used for up to 80 tool holders HSK-A63 and HSK-T63 shafts. Due to the large stock of tools, the tooling times are reduced to a minimum. The tool cabinet is built into the machine, so to speak.

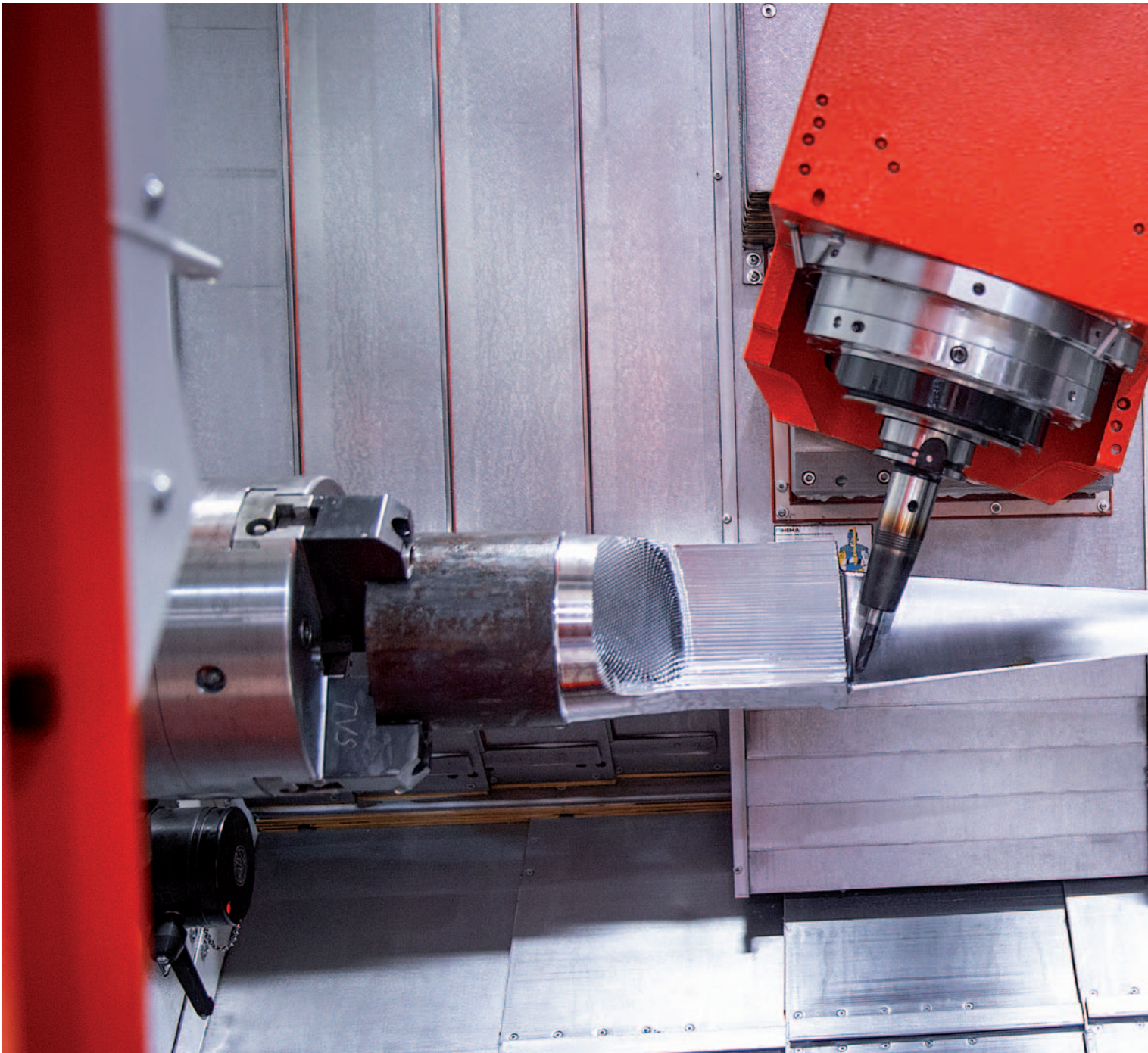

Parts catcher. The HYPERTURN 65's electro-pneumatic parts catcher is controlled using M functions. When needed, it traverses to the front of the work area and pivots to the spindle center. The finished part is removed from the clamping device and transferred to the catcher tray. The parts catcher then moves back to its initial position and the part is tipped onto a conveyor belt.

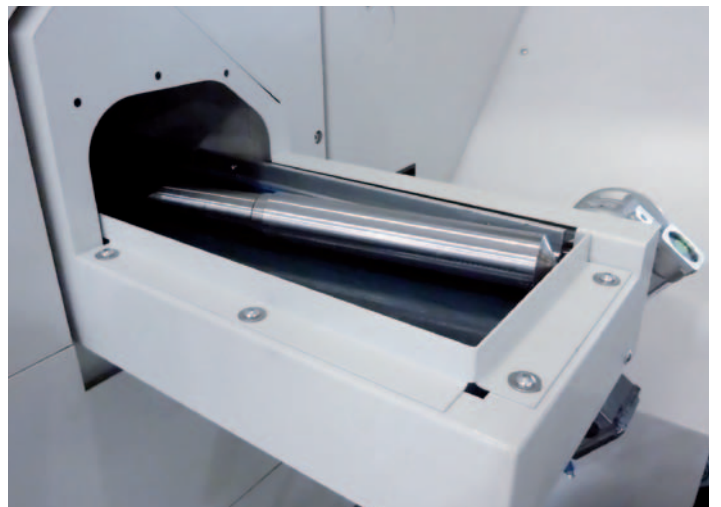

Finished part conveyor belt. On the conveyor belt within the machine casing, arranged lengthwise, with a storage surface of 1400 x 180 mm, the work pieces are put down damage free.



Paper-band filter system. A Paper-band filter system for coolant processing is an advantageous solution for the serial production of turned/milled parts made of aluminium, brass, steel or grey cast iron. It increases both the coolant volume and the cooling lubricant's service life. Coolant pressures of 40, 60 or 80 bar can be implemented.

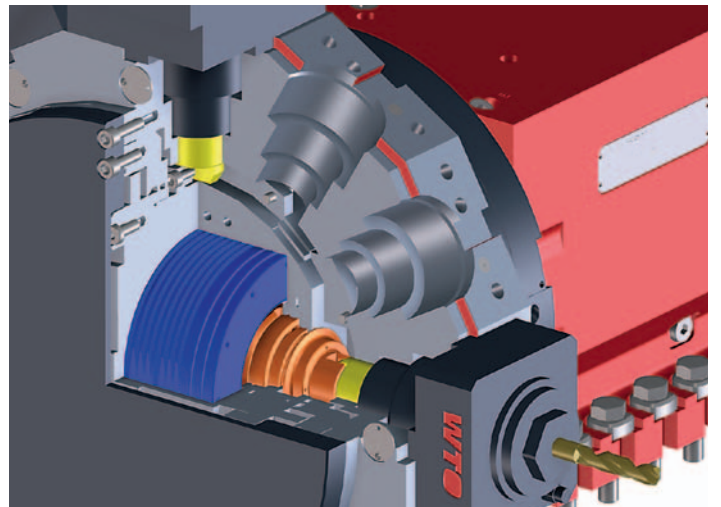

BMT Turret. Economic production of elaborate turned/milled workpieces, the major part of which involves milling operations, becomes possible with the optionally available BMT Turret with water-cooled direct drive. With a maximum of 12,000 rpm, 30 Nm and 10 kW, this turret provides the ideal prerequisites for complete machining.

The EMCO gantry loader. Individual process optimization.

1 GANTRY LOADER

2 PALLET MAGAZINE



Advantages

- Fully automatic loading and unloading of the workpieces
- Multi-channel Sinumerik control incl. user cycles
- Seamless interplay between the machine tool and the loading device
- Varied possibilities of customer-specific adaptation
- Possibility of integration of measuring station, signing station, cleaning station, etc.
- Short spare time due to a load

Automatic Return on Investment

Workpiece magazine

Blank-specific pallet attachments enable oriented loading of blanks into the machine and increase the parts stock for unmanned production. Changeover times are reduced or eliminated thanks to the perfect adjustment to the customer's parts.



4-station pallet attachment for tees



6-station pallet attachment for articulated brackets

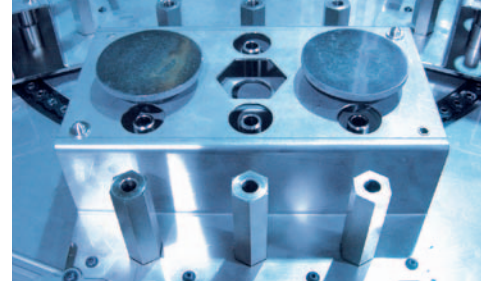

Multi-pallet attachment for a family of parts



4-station pallet attachment for valve caps



20-station pallet magazine with customer-specific pallets

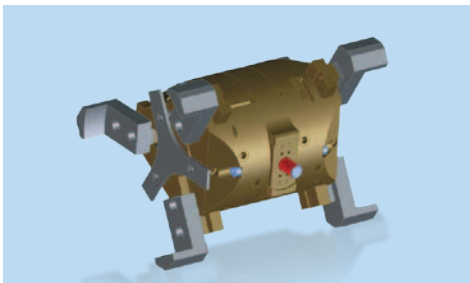

2 x 3-jaw double gripper head

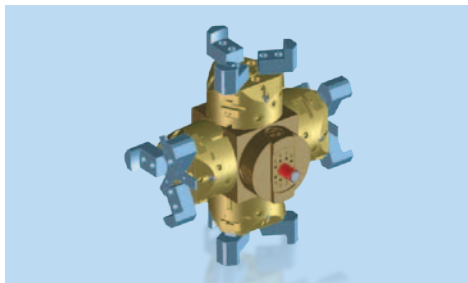

4 x 3-jaw gripper head

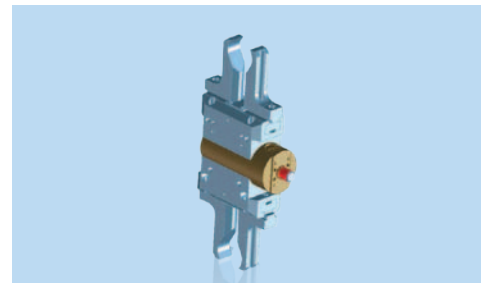

Shaft gripper head

EMCO bar loaders



EMCO short bar loader. In view of the ever-increasing pressure on floorspace for machines, EMCO has developed the most compact short loader on the market: the EMCO SL1200.

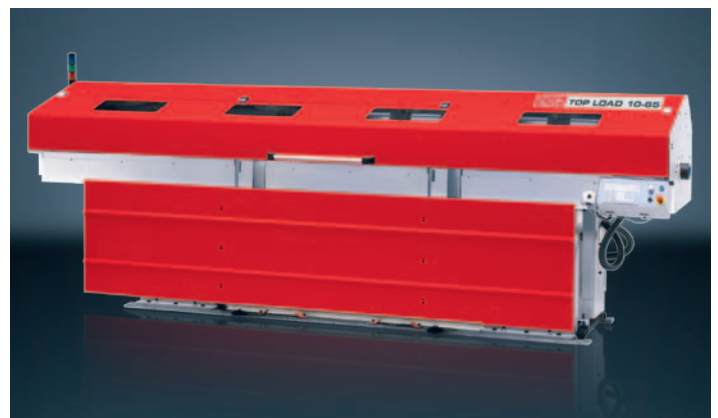

EMCO Top Load 10-65. 3-metres of bar material may be loaded into the machine in a fully automated way. Multi-Level material supports enable unmanned operation for an even longer period of time.

Quality Components

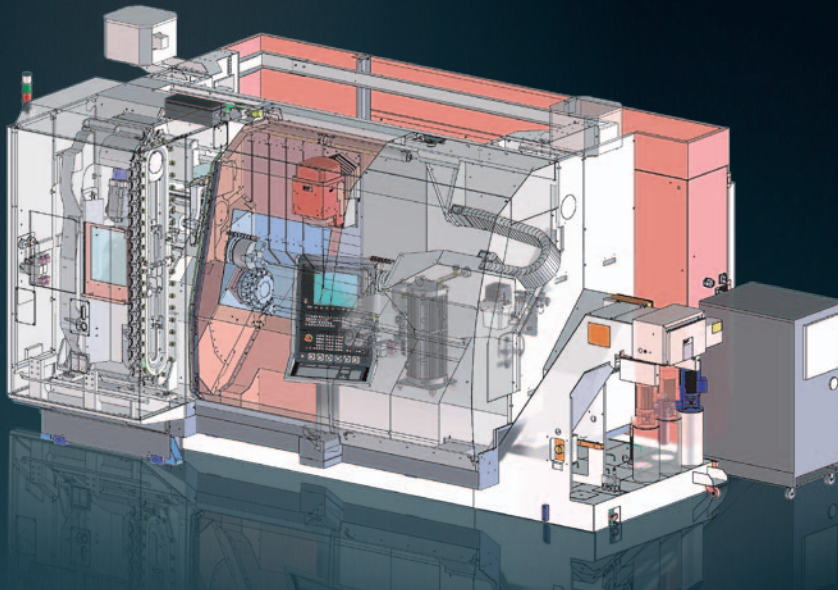

Coolant pumps

Low-maintenance immersion pumps for pressures of up to 25 bar and flow rates of up to 1500 l/min provide optimum conditions for machining and enable reliable chip transportation.



Clamping cylinder / chuck

Hydraulically activated clamping cylinders and chucks guarantee the precise, safe clamping of work pieces. Programmable sensors are used for stroke monitoring. There is no need for time-consuming adjustments of contactless limit switches.



Tool holder

Innovative, fully developed tool holder systems form the basis for cost-effective machining. High changeover accuracy and stability result in short setup and cycle times.



Headstocks

The design and manufacture of headstocks are two of EMCO's core competencies. During engineering, the focus is on precision, robustness, high rigidity, precise rotational characteristics, and a long service life.



Hydraulic systems

Compact dimensions, quiet operation, and high energy efficiency - just some of the advantages of the hydraulic assemblies used by EMCO. Monitored pressure switches prevent the need for time-consuming manual pressure adjustments.

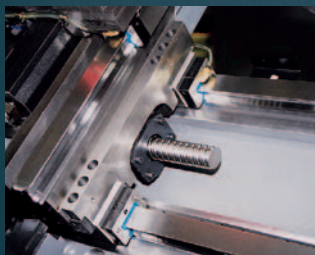

Machine bases and slides

When matching components, we place great value on high stability, good damping characteristics, and a thermoneutral design. We achieve high stability through a shorter force flow, thermal stability through symmetry, and dampening through the materials and interfaces selected.

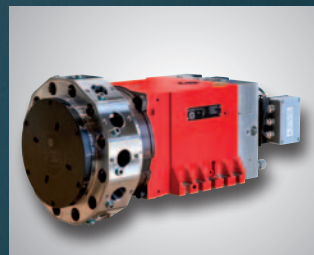

Tool turret

Rapid-indexing turrets with adjustable swivel speeds and milling drives represent the current state of the art. The backlash-free milling drive is not only ideal for milling and drilling, but also for rigid tapping, hobbing, and polygonal turning.



Ball screws and roller guides

Highly precise and generously dimensioned guide rails and ball screws with optimal pretensioning form the basis for the machining of precision parts



Chip conveyor

Slat band conveyors allow for flexible implementation and the safe removal of chips. A monitored overload clutch prevents damage from improper use.

Minimum use of resources for maximum profit.



At EMCO, we take a consistent, responsible approach to the use of resources in machine tools in order to safeguard long-term investments. From the development of our machines through to their construction and manufacture, we place a strong focus on the sensible and sparing use of raw materials and energy. This enables us to achieve parallel savings in two areas:

1. Reduction in the basic power consumption of machine tools, e.g. assemblies are switched on and off as required and the installed connected loads are kept to a minimum.
2. Reduction in variable consumption: This can be seen in the lighter axes, energy recovery system, increased rate of good parts, and the shorter process chain enabled by complete machining.

Through these measures, which are constantly being refined and further optimized, EMCO truly demonstrates that its slogan of „Designed for your Profit“ is not just an empty promise: EMCO products help save the environment and provide intelligent customer savings without compromising on quality and flexibility.

[Regenerative drive system]

Kinetic energy is converted into electrical energy and fed back into the grid.
Savings of up to 10%

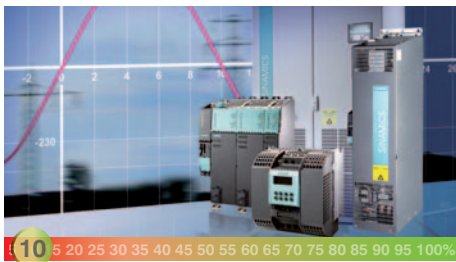

[Compact hydraulics unit with pressure accumulator]

Thanks to its accumulator charging system, the pump only runs when required. If the pressure accumulator is full, the pump switches over to closed loop circulation.
Savings of up to 90%



[Roller guides]

Extremely low friction losses thanks to rolling friction. Highly dynamic performance with minimal lubricant consumption.
Savings of up to 50%

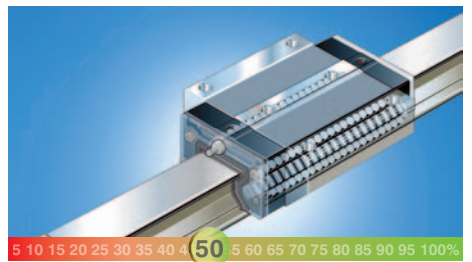

[Structurally optimized mechanics]

FEM analysis is used to optimize the relevant components in terms of their rigidity while simultaneously reducing their weight.
Savings of up to 10%

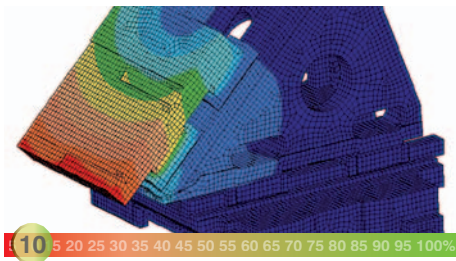

[Highly efficient motors]

The use of energy-efficient motors (IE2) in the coolant preparation area guarantee highly cost-effective operation.
Savings of up to 10%



[Synchronized chip conveyor]

Programmable interval times enable optimal use of the chip conveyor independently of the machining process.
Savings of up to 95%

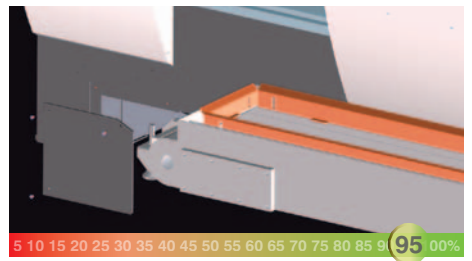

[Intelligent standby concepts]

Reduced consumption by automatically switching off ancillary units and machine space/screen illumination after a defined period of inactivity on the control panel.
Savings of up to 50%



[Virtual machine]

Significant reduction in the setup and running-in times on the machine through the use of highly developed simulation and programming software.
Savings of up to 85%

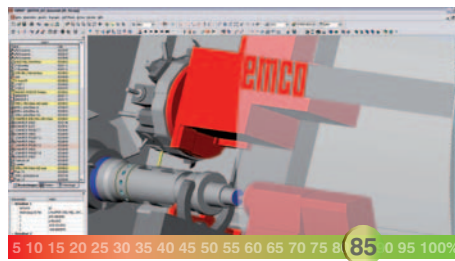

[Intelligent energy management]

Intuitive data entry screens for activating the individual energy-saving functions.
Savings of up to 70%

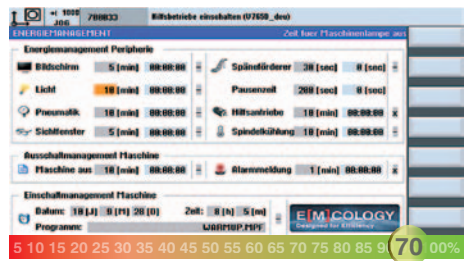



DASHBOARD – For a Quick Overview of the Machine Status

Clear and compact processing of all relevant machine and NC data depending on the configuration of the machine (number of tool systems, spindles, ...) and the active operating mode (JOG, MDA, AUTO). Know at a glance whether everything is OK or whether the machine operator will be required to interact.



emcoCONNECT's hardware basis is a 22" industrial touch control panel combined with an industrial PC (IPC).

Highlights

- Direct interaction between EMCO Apps and the control
- Intuitive user interface optimized for touch control
- Range of available applications is continuously being expanded
- Customised and project-specific applications
- Optimized for the EMCO machine range
- emcoCONNECT allows for easy and quick configuration and updating

er“ for fire production flow

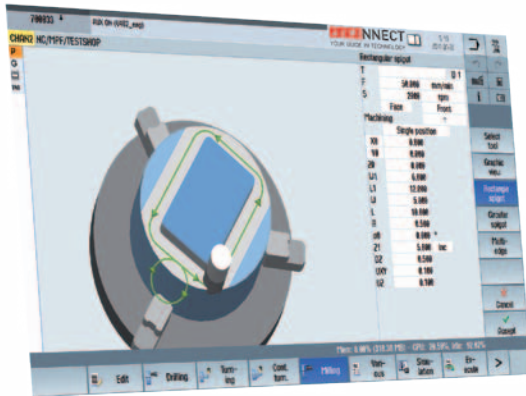

SINUMERIK - the Control and the Machine's Centerpiece

Thanks to the App Launcher operators may switch between the emcoCONNECT Apps and the control at any time. All it takes to do so is a click on the emcoCONNECT logo. To improve the work processes on the machine the control can, as shown in the picture, be operated in full screen mode or in interaction with practical apps (sidebar).

MACHINE DATA – All Data related to Productivity at a Glance

Operating data collection to inform the user about the current production status and OEE (Overall Equipment Effectiveness) values full screen or sidebar.



DOCUMENTS – A Digital and Expandable Document Collection Customised to Suit Your Individual Needs

To display PDF documents such as machine documentations, programming instructions, process descriptions ... Including favourites management - full screen or sidebar

Virtual workflow.

Real benefits.

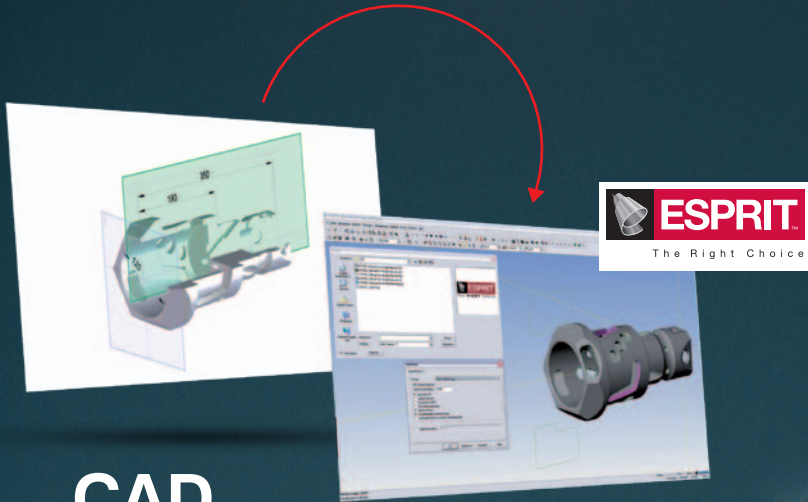

CAD

Direct CAD data import

- AutoCAD (DWG)
- Parasolid®
- Solid Edge®
- Solid Works®
- ACIS® (SAT)
- Optional interfaces: CATIA®, Pro/ENGINEER®, STEP, STL,...

CAM

- 2-22 axis turning
- 2-5 axis milling
- Multi-tasking of turning and milling
- 3D machine space simulation
- Certified post-processors

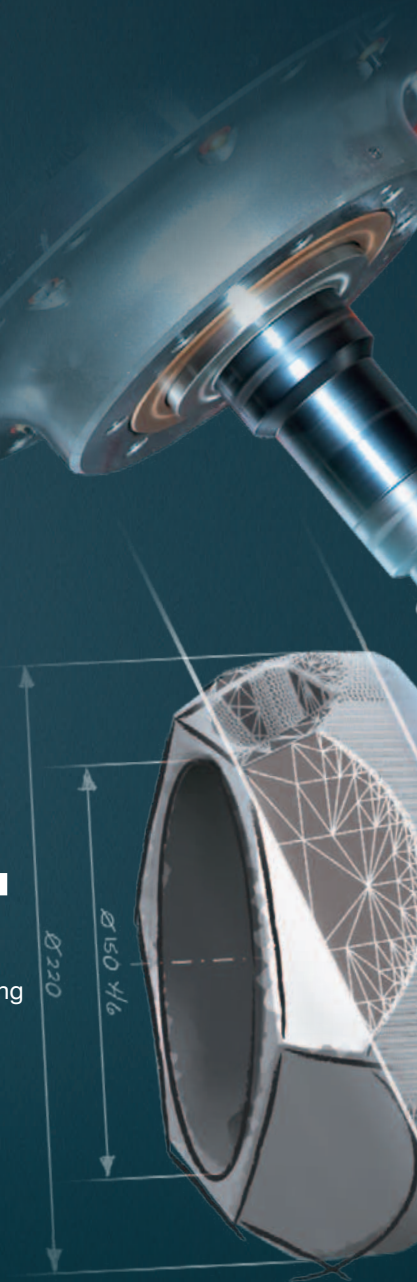
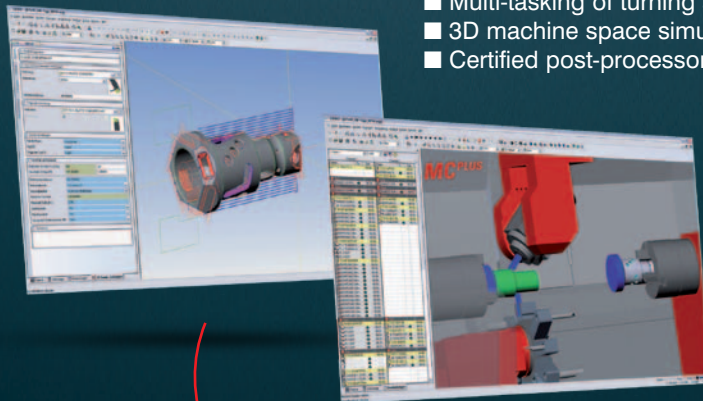

fits.

The Esprit CAM system offers high flexibility and process security, a comprehensive selection of machining cycles, maximum tool control, and cross-machine technology for your entire production facility. EMCO CPS Pilot provides for a 1:1 mapping of the real machine for defining and testing processes, optimizing machining sequences, and training new operators.



CPS

- 1:1 simulation with collision detection
- Direct connection to CAM ESPRIT
- Process optimization
- Reverse simulation of existing NC codes
- Reduction in scrap rates
- Training on the virtual machine
- Simulation of loading systems (e.g. EMCO gantry loader)

emcoCPS | Pilot
Die virtuelle Maschine

Production

- Reduction in set-up costs
- Reduction in downtimes
- Reduction in repair costs
- Optimum machine utilization



Work area layout and turret clearance

HYPERTURN 65

VDI-30

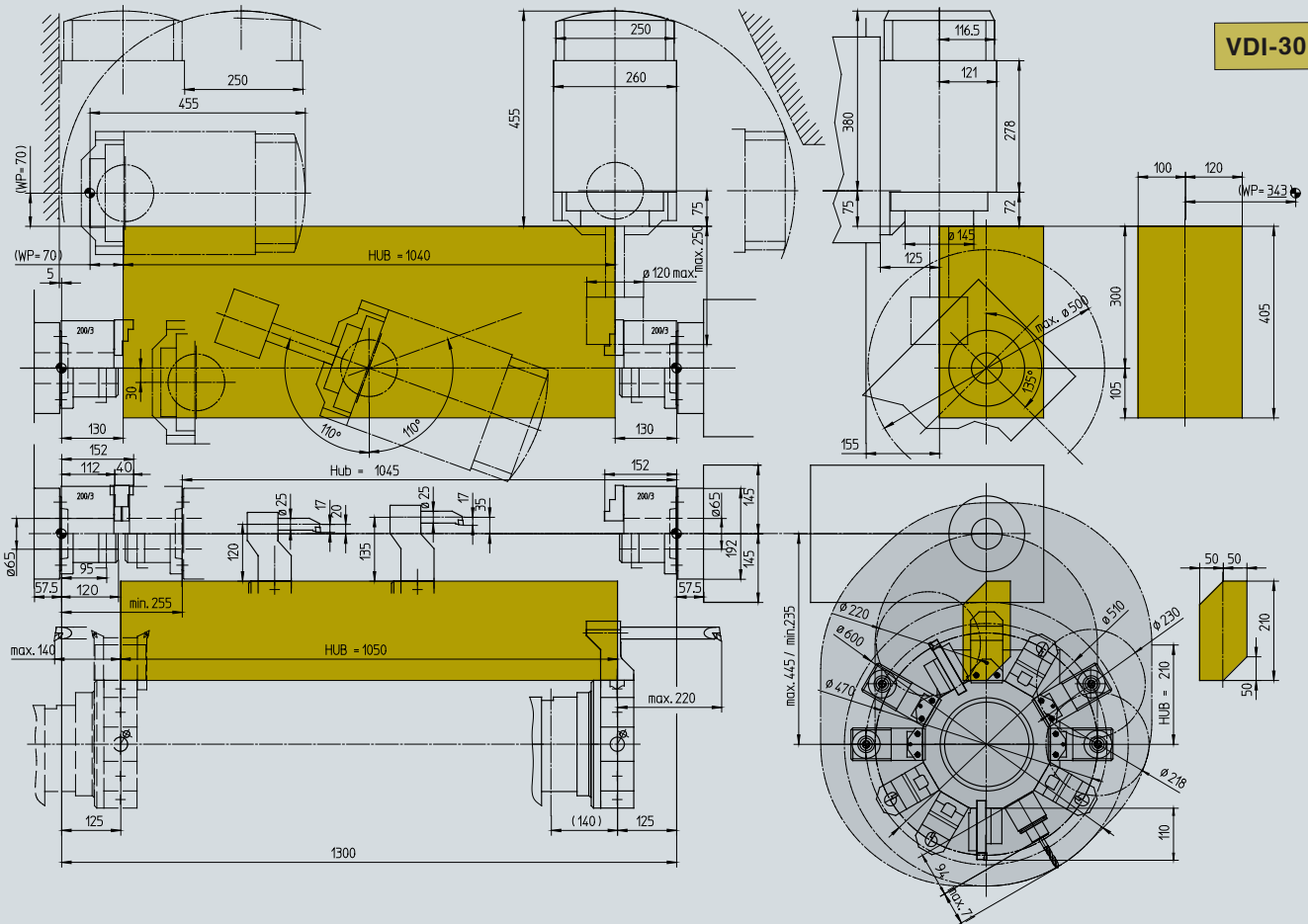

Indications in millimetres

Power and Torque

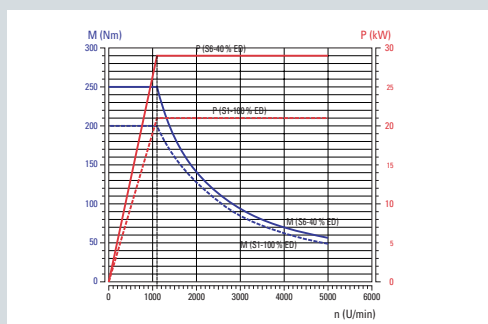

Main spindle / Counterspindle

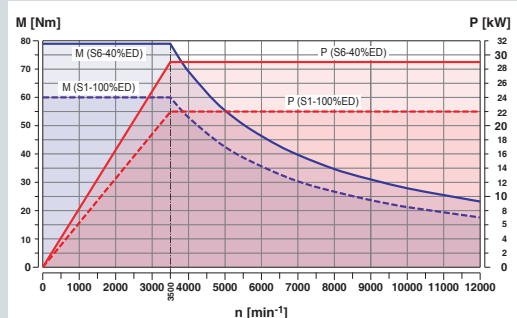

Millingspindle

Machinelayout HYPERTURN 65

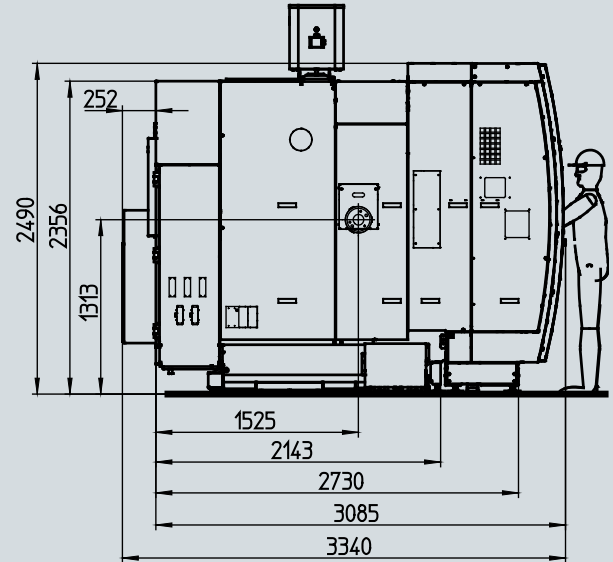
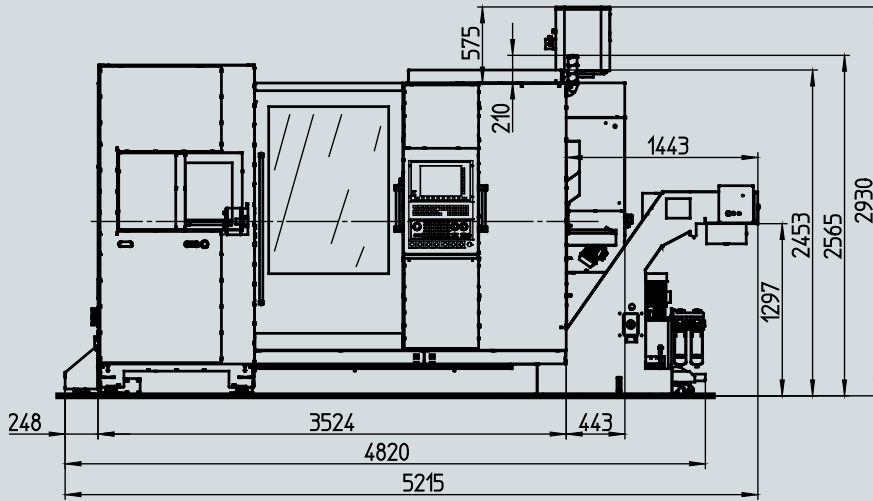

Indications in millimetres

Power and Torque

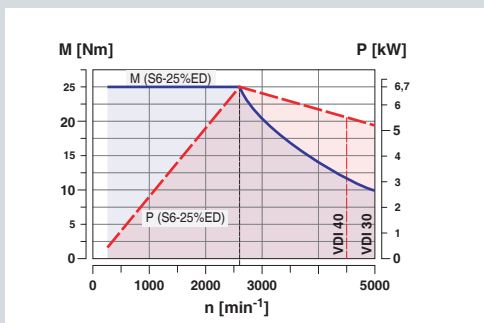

Milling drives in tool turret with VDI 30/40

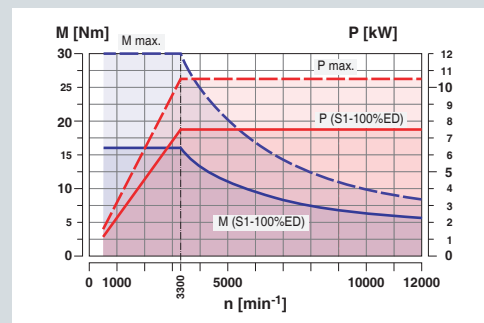

Direct milling drives in tool turret with BMT55P

HYPERTURN 65 Powermill

Technical Data

Work area

Swing over bed	500 mm
Distance between spindle noses	1300 mm
Maximum turning diameter	500 mm
Max. part length	1040 mm
Max. bar-stock diameter	65 (76/95) mm

Travel

Verfahrweg X1 / X2	405 / 210 mm
Traverse path Z1 / Z2	1040 / 1050 mm
Traverse path Y1 / Y2	220 / 100 mm
Traverse path counter spindle Z3	1045 mm

Main spindle

Speed range (infinitely variable)	0 – 5000 (3500/4000) rpm
Maximum torque	250 (360) Nm
Spindle nose DIN 55026	A2-6 (A2-8)
Spindle bearing (inside diameter)	105 (130/140) mm
Spindle bore (excluding draw-back rod)	Ø 73 (86/106) mm

Counter spindle

Speed range (infinitely variable)	0 – 5000 (3500/4000) rpm
Maximum torque	250 (280) Nm
Spindle nose DIN 55026	A2-6 (A2-8)
Spindle bearing (inside diameter)	Ø 105 (130/140) mm

C-axes

Resolution	0,001°
Rapid traverse	1000 rpm

Drive power

Main spindle (AC integrated-spindle motor)	29 (37) kW
Counter spindle (AC integrated-spindle motor)	29 kW

Milling spindle - Powermill

Speed range	0 - 12000 (18000) rpm
Maximum torque	78 (38) Nm
Maximum Drive power	29 (39) kW
Type of tool shank	HSK-T63

B-axis

Travel range	220°
Holding torque of clamp	4000 Nm
Interpolating drive torque	332 Nm

Tool magazine

Tool storage capacity	20 / 40 / 80 mm
Max. tool diameter	Ø 80 (Ø 120) mm

Tool magazine

Max. tool length	250 mm
Max. tool weight	5 kg

Tool turret

Number of tool stations	12
VDI shaft (DIN 69880)	30 (40) mm
Tool cross-section for square-shank tools	20 x 20 (25 x 25) mm
Shank diameter for boring bars	32 (40) mm
Tool indexing time	0,7 sec.

Driven tools

Speed range	0 – 5000 (4500) rpm
Torque	25 Nm
Drive power	6,7 kW

Tool turret with BMT-interface and direct drive

Number of tool positions	12
Precision interface	BMT-55P
Tool cross-section for square-shank tools	20 x 20 (25 x 25) mm
Shank diameter for boring bars	40 mm
Tool indexing time	0,5 sec
Speed range of driven tools	0 – 12000 rpm
Torque of driven tools	30 Nm
Drive power of driven tools	10 kW

Feed drives

Rapid speed X1 / X2	30 m/min
Rapid speed Z1 / Z2 / Z3	30 m/min
Rapid speed Y1 / Y2	12 m/min
Feed force X1 / X2	5000 N
Feed force Z1 / Z2	8000 N
Feed force Y1 / Y2	7000 N

Coolant system

Tank capacity	450 (300) l
Coolant pumps for the tool systems	2 x 14 bar
Scavenge pumps for the work area	2 x 3,7 bar

Power consumption

Connected load	50 kVA
Compressed air	6 bar

Dimensions

Height of center above floor	1316 mm
Overall height	2490 mm
Required space L x D (without chip conveyor)	5300 x 3340 mm
Total weight	12250 kg

Safety devices CE compliant