

Hobbing machines LC 200-500

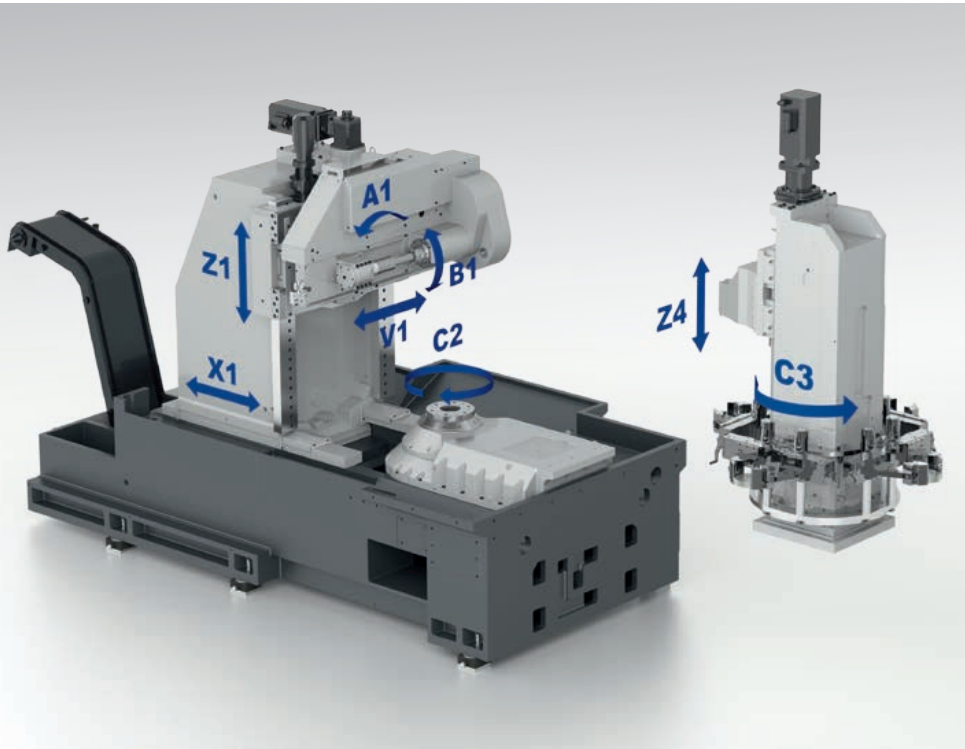

LIEBHERR

The Machine Concept



Machine Concept

Liebherr hobbing machines are optimized for universal gear applications. Our high-performance hobbing machines are productive and machine in the highest quality.

- 6 CNC axes
- Optimised stiffness of the machine bed with FE Analysis model
- Thermo-symmetrical machine design for constant high quality
- Safe and problem-free removal of chips
- Wet and dry processing
- High flexibility for different processes:
 - Gears, shafts, worm gears
 - Cluster gearing
 - Skiving
 - Positioned/Oriented gear teeth
- Hook-ready machine with compact floor space suitable for straightforward implementation
- Hand or machine-internal crane loading

Axes

- | | |
|---------------------------------------|---|
| X1 - Radial movement of spindle slide | C2 - Rotary movement of workpiece |
| V1 - Tangential movement of tool | A1 - Swivel motion of tool |
| Z1 - Axial Travel of Hob Head | Z4 - Vertical movement of steady column |
| B1 - Rotary movement of tool | C3 - Rotary movement of ring loader |

Steady column and ring loader

The optional steady column can be supplied with ring loader for automatic loading or without ring loader for manual loading.

The ring loader makes fast loading and unloading possible. Depending on the workpiece, the loading time can be less than 2 seconds. Grippers are available as parallel grippers (e.g. gears) or swivel grippers (e.g. shafts), where by grippers can be changed quickly without tools. The ring loader can be loaded with workpieces with a weight of up to 100 kg.

- Traveling distance: 540 mm (standard)
- Traveling distance: 750 mm (option)

Table drives and hob heads

gear drive

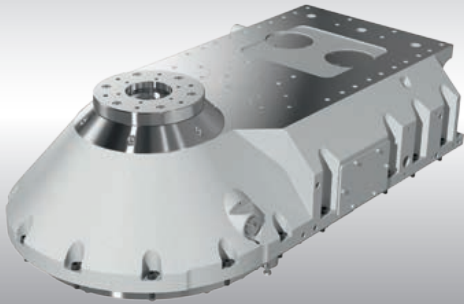

gear drive

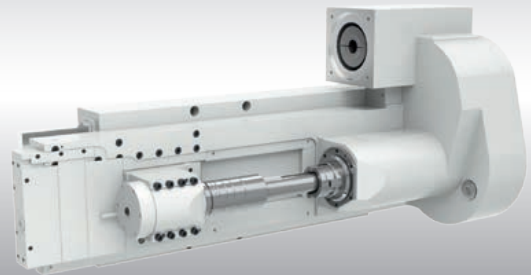

direct

Machine table

A workpiece drive with absolutely zero backlash is needed for machining gears. The table drive with pre-loaded helical gears is available when using conventional technology. For high performance cutting (HPC) there is an ultra-dynamic direct drive available which satisfies all requirements with respect to speed and precision.

direct

Hob heads

For most applications with high torque requirements, the milling head features a stepped gear mechanism which allows different transmission ratios to be selected. SK tapers, steep SK tapers and straight shank collets are available as the interface for holding the tool. For very high spindle speed requirements, a milling head with direct drive is also available.

Drive	Gear drive	Direct
Driving power (kW)	5.65/11.80	15.0
Speed (1/min)	100/200	400

Drive	Gear drive	Direct
Driving power (kW)	14/27	26
Speed (1/min)	500/750 1,500/3,000	4,500

Chamfer/Deburring devices

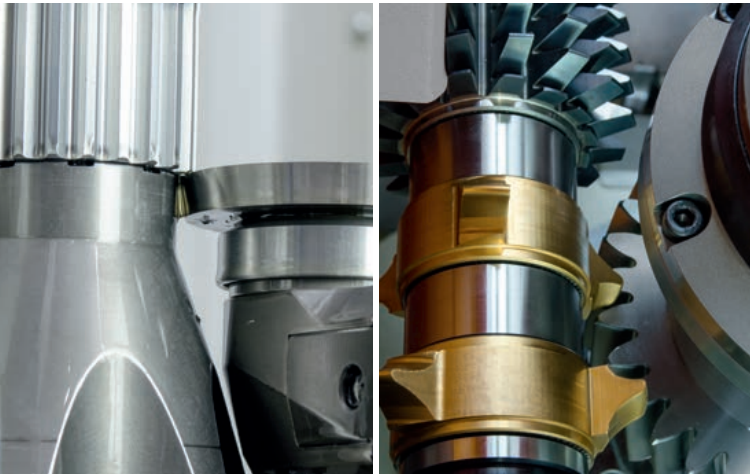

Chamfer/Deburring in the working area

Rough deburring

Rough deburring can be integrated into the working area and is simultaneously performed.

ChamferCut

The established ChamferCut process offers many benefits:

- High chamfer quality and precise chamfer geometry
- No tooth-flank bulging or material deformation
- Very long tool life (also with dry cutting)
- No needle chips
- ChamferCut is easy to sharpen
- Economical production solution for chamfer/deburring



Simultaneous chamfer/deburring in a second machining position

Roll-press Chamfer/Deburring

Roll-press device for chamfering the tooth edges and simultaneously removing secondary burrs. Suitable for shafts and gears. The procedure makes very short chamfering times possible and can thus be run simultaneously (in parallel to the hobbing process).



Chamfer/Deburring with milling cutters

Chamfering with end mills is highly flexible with respect to the workpiece geometry and insensitive to material strength. Chamfering runs simultaneously if the cycle time is sufficient. The chamfer size can be adjusted by the contact force and the rotational speed of the tool. The root of the tooth can be chamfered without difficulty.



ChamferCut

In addition, Liebherr hobbing machines are available with a separate ChamferCut unit for simultaneous chamfering in a second machining position. After hobbing with a single-cut strategy, precise and reproducible chamfers are created with appropriate chamfer cutters. Chamfering with ChamferCut in the separate unit has the same benefits as the ChamferCut integrated into the working area, and is an economical solution for chamfer/deburring in high production.

Technical Data

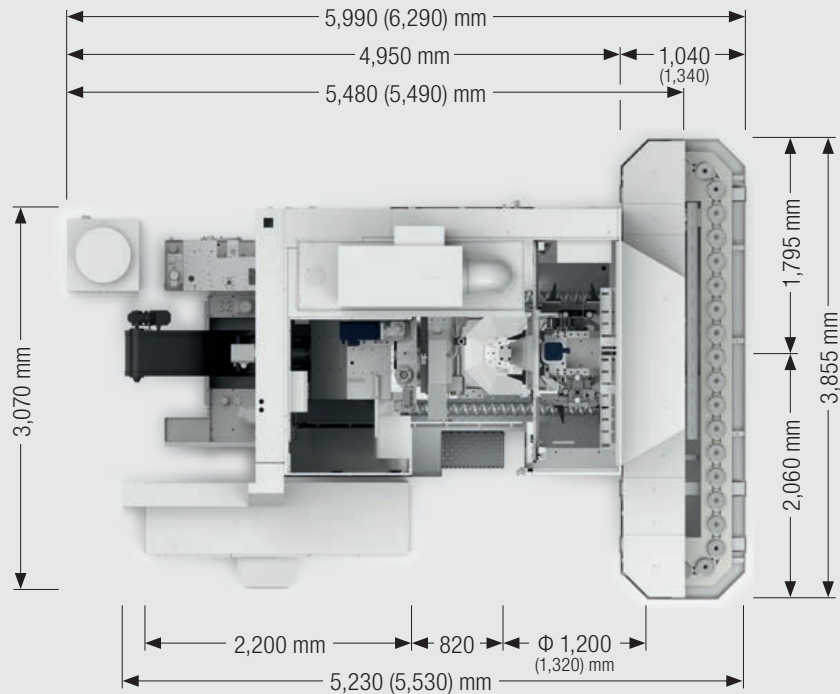

Height 3,110 mm

		LC 200	LC 300	LC 380	LC 500
Max. workpiece diameter	mm	200	300	380	500
Max. nominal module	mm	7/12	7/12	7/12	7/12
Workpiece weight	kg	100	100	100	100
Max. workpiece length (manual loading)	mm	680 (1,200)	680 (1,200)	680 (1,200)	680 (1,200)
Max. hob slide travel (axial travel)	mm	600	600	600	600
Table diameter	mm	180	250	320	320
Table speed	min ⁻¹	100/200/400	100/200/400	100/200/400	100/200/400
Drive power of table	kW	5.56/11.8/15.0	5.56/11.8/15.0	5.56/11.8/15.0	5.56/11.8/15.0
Centre distance hob/work table	min. mm	15	15	15	15
	max. mm	400	400	400	400
Hob head swivel angle	Degrees	± 35/45	± 35/45	± 35/45	± 35/45
Hob arbor main bearing		Cylindrical, HSK, SK			
Max. shift travel	mm	200/300	200/300	200/300	200/300
Max. hob diameter	mm	160/220	160/220	160/220	160/220
Max. hob length	mm	230/330	230/330	230/330	230/330
Max. Hob speeds	min ⁻¹	500/750/1,500/3,000			
Driving power hob spindle	kW	14/27	14/27	14/27	14/27
Weight of machine with tailstock column	ca. kg	16,000	16,000	16,000	16,000
Total connected load	ca. kVA	35-50	35-50	35-50	35-50

Additional features

Software/control technology

The new, user-friendly LHGe@rTec® interface makes it much easier to operate the gear cutting machine and has many advantages for the operator:

- Individual configuration
- Intuitive operation
- User guidance for process and change-over procedures
- Mathematical analysis
- Touch screen
- Graphical input support
- Incorporation of additional documentation (e.g. fixture layout, hob tool/arbor assembly, etc.)
- Integrated webcam
- Siemens 840 D Solutionline

The Collision Control software package is available to minimise damage in the event of unexpected impact between tool and clamping fixture or spindle and machine table.



Energy and resource efficiency

Liebherr has analysed the energy usage of its gear cutting machines in extensive tests. An important conclusion is that every 100 watts saved reduces the environmental impact, and justifies evaluation!

- Regenerative drive technology
- Use of efficient control cabinet chillers
- LED lighting
- Coolant supply and treatment with speed-controlled pumps

Also available:

- Pneumatic-free automation (conveyor with metering unit)
- Monitoring of air consumption with leakage monitoring
- Reduced oil loss
- Workpiece spinning station and chip centrifuge
- Water/air heat exchanger with regulated fan (energy and noise)
- Incremental shutdown of auxiliary drives when inactive

BLUECOMPETENCE

Alliance Member

Partner of the Engineering Industry Sustainability Initiative

External Automation Possibilities

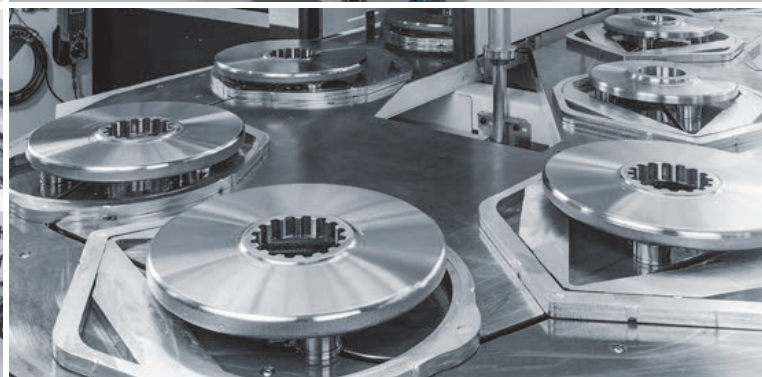
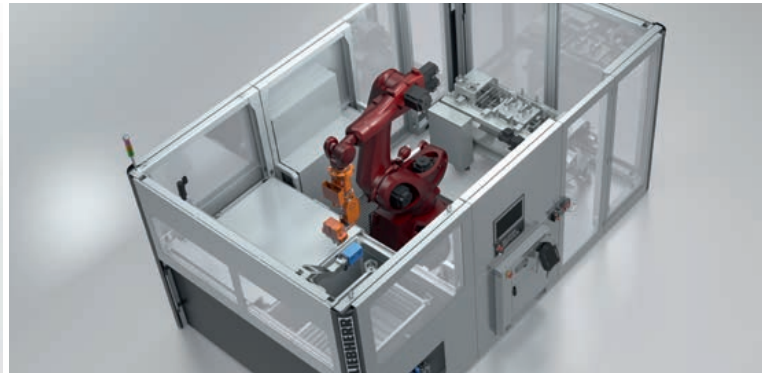

Palletizing Cell (LPC)

Standardized transport containers with basket technology facilitate a uniform approach to logistics, as well as flexible future-oriented production.

Plastic Chain Conveyor (KKB)

The plastic chain conveyor is available in the standard version for workpieces up to 20 kg in weight and in the heavy duty version for workpieces up to 180 kg in weight, and is designed to transport any number of irregularly shaped workpieces without them coming into contact with each other.

Robot Cell (LRC)

Hook-ready robot solution in modular design replaces complex sorting systems, increases productivity, and alleviates burden on personnel.

Drag Frame Conveyor (SRB)

Drag frame conveyors serve to transport parts with a flat surface, e.g. bore-type gears, hubs or rings. The workpieces are dragged by a frame that is connected to a chain.

Hinged Chain Conveyor (SKB)

With the aid of hinged chain conveyors, it is possible to transport workpieces with a flat surface, e.g. bore-type gears. Depending on the scenario, multi-track versions are also possible.

Machine Tools and Automation Systems from Liebherr

Liebherr employs roughly 1200 staff in the area of machine tools and automation technology and has production facilities in Kempten and Ettlingen (Germany), Collegno (Italy), Saline (Michigan, USA) and Bangalore (India). They are supported by expert and reliable marketing and service specialists at a large number of locations worldwide.

With over sixty years of industrial experience, Liebherr is one of the world's leading manufacturers of CNC gear cutting machines, gear cutting tools and automation systems. The company's innovative products are the result of pioneering ideas, highly qualified staff and state-of-the-art manufacturing systems at each of their locations. They are characterised by economy, ease of use, quality and reliability in combination with a high degree of flexibility.



System Solutions in the Area of Machine Tools

Included in the production programme are gear hobbing machines, gear shaping machines and generating- and profile grinding-machines, all noted for their high degree of stability and availability. Particular importance is attached to the energy efficiency of the machines.

Gear cutting machines from Liebherr are supplied to renowned manufacturers of gears and gearboxes and large-scale slewing rings worldwide. They are in demand primarily from the automotive and construction machinery industries and also increasingly from the wind power industry for the manufacture of gears for wind turbines.

High Quality Gear Cutting Tools

Liebherr manufactures high quality, precision tools for the soft and hard machining of gears and all Liebherr gear cutting machines are fitted with Liebherr tools. The range also includes Lorenz shaping tools and products customised for specific customer applications.

Automation Systems for a Broad Range of Applications

Liebherr has a wide range of products for linear robots, pallet-handling systems, conveying systems and robot integration for projects in all areas of production and can provide above-average availability of systems.

www.liebherr.com

Liebherr-Verzahntechnik GmbH
Werk Ettlingen
Gear Cutting Tools
Hertzstraße 9-15
76275 Ettlingen, Germany
☎ +49 (0)7243 708-0
Fax +49 (0)7243 708-685
tools.lvt@liebherr.com

Liebherr-Utensili S.r.l.
Gear Cutting Tools
Via Nazioni Unite 18
10093 Collegno TO, Italy
☎ +39 (0)114 248711
Fax +39 (0)114 559964
info.lut@liebherr.com

Liebherr-Gear Technology Inc.
Machine Tools
Liebherr Automation Systems Co.
Automation Systems
1465 Woodland Drive
Saline, MI 48176-1259, USA
☎ +1 7344 297225
Fax +1 7344 292294
info.lgt@liebherr.com

Liebherr-Machine Tools India Pvt. Ltd
Machine Tools
353/354, 4th Main, 9th Cross, 4th Phase
Peenya Industrial Area
Bangalore - 560 058, India
☎ +91 (0)80 41 273033
Fax +91 (0)80 41 272625
info.mti@liebherr.com

Liebherr-Verzahntechnik GmbH
Verzahntechnik und Automationssysteme
Kaufbeurer Straße 141, 87437 Kempten, Deutschland
☎ +49 (0)831 786-0, Fax +49 (0)831 786-1279
www.liebherr.com, E-Mail: info.lvt@liebherr.com